

## WDTAC – Forest Harvesting and Silviculture Module

*Table 1. Levels of Disturbance for Unprotected Workers in Various Work Activities*

Wind Speed Equivalency (km/h)	Level of Disturbance*	Example of Work Activities
<40	1 (Table 3)	<ul style="list-style-type: none"> <li>• tree planting</li> <li>• brushing</li> <li>• tree pruning (stems &lt;20 cm dbh)</li> <li>• use of light-duty machinery (e.g., weed whips, brush saws)</li> <li>• road travel with heavy vehicles (&gt;5500 kg GVWR) on ballasted and PERMANENT roads (a cleared right-of-way)</li> <li>• fire control with hand tools and/or water hoses</li> </ul>
	2 (Table 4)	<ul style="list-style-type: none"> <li>• road travel with heavy vehicles (&gt;5500 kg GVWR) on non-ballasted, TEMPORARY roads (no cleared right-of-way)</li> <li>• maintenance or construction activities without heavy equipment (e.g., small machines such as "bobcats")</li> <li>• tree pruning (stems &gt;20 cm dbh)</li> <li>• juvenile spacing or slashing (stems &lt;15 cm dbh)</li> <li>• tree bucking</li> </ul>
40–65	3** (Table 4a)	<ul style="list-style-type: none"> <li>• tree falling (any tree &gt;15 cm dbh)</li> <li>• cable yarding</li> <li>• ground skidding</li> <li>• mechanical harvesting and forwarding</li> <li>• helicopter logging with NO workers exposed to rotor wash</li> <li>• use of light and intermediate helicopters where workers are exposed to rotor wash (e.g., helipads)</li> <li>• mechanical site preparation with heavy machinery</li> <li>• maintenance or construction activities with heavy equipment</li> </ul>
+65	4 (Table 5)	<ul style="list-style-type: none"> <li>• trees adjacent to corridors in partial-cut cable logging operations</li> <li>• harvesting operations in structurally damaged stands (e.g., wildfire burns)</li> <li>• blasting</li> <li>• helicopter logging with workers exposed to rotor wash</li> <li>• use of medium and heavy helicopters where workers are exposed to rotor wash</li> </ul>

\* A dangerous tree assessment is only valid for the lowest level of disturbance at which the assessment has been done.

\*\* If trees CANNOT be felled and yarded away from adjacent standing timber, then default to Level 4 disturbance.

Table 1A. Influence of Wind Speed on Level of Disturbance

Wind Speed (km/h)	Description	Level of Disturbance Equivalency
0–40	<b>light breeze</b> (dust and loose paper raised; small branches move) to <b>fresh breeze</b> (small trees sway; tops of large trees sway)	1–2
40–65	<b>strong breeze</b> (small branches fly in the air; whole trees in motion; resistance felt when walking against wind)	3
65+	<b>gale</b> (branches broken off trees; walking impeded)	4

Table 1B. Helicopter types

Helicopter Category	Passenger Capacity	Lift Capacity
Type 1 (Heavy)	15+	Exceeds 2720kg (6000 lbs)
Type 2 (Medium)	9 – 14	1135 – 2720kg (2500-6000 lbs)
Type 3 (Intermediate)	5 - 8	680 – 1134kg (1500 – 2500 lbs)
Type 4 (Light)	1 - 4	Not exceeding 680kg (1500 lbs)

The following listing provides examples of common aircraft by helicopter type, and is a useful guide when determining the appropriate level of disturbance for the type of aircraft being used.

**Light Category:** Jet Ranger (Bell 206), Hughes 500, Hiller 12, EC 120, R22 & R44

**Intermediate Category:** Long Ranger, A-Star (AS350), Bell 407, EC 130

**Medium Category:** K-Max, Bell 204, 212, 205

**Heavy Category:** Bell 214, Kamov, Sikorsky 61 & 64, BV 107 & 234

### Summary of Assessment Requirements

All work activities EXCEPT those defined as “very low risk” require a pre-work inspection by a qualified person to determine if there are any trees that might endanger workers. A summary of activity level assessment requirements is shown below.

- **Very Low Risk (VLR) Activities** — No pre-work site inspection is required.
- **Level 1 Disturbance Activities** — A pre-work inspection by a qualified person is required. If trees with significant tree hazards (see Table 3) are observed, the appropriate safety procedures must be taken before work activities begin.
- **Level 2, 3 or 4 Disturbance Activities** — A pre-work inspection by a qualified person is required. If “suspect” trees (see Table 4, 4A, 5) are identified by a qualified person, then further assessment by a certified danger tree assessor is required and the appropriate safety procedures must be taken BEFORE work activities begin.

### Steps Required to Determine Tree Danger Rating:

1. Determine the level of ground disturbance and visitor exposure (refer to Tables 1, 1A, 1B) and conduct a site assessment overview (refer to Table 2)
2. Conduct tree assessments (refer to Tables 3, 4, 4A and 5)
3. Make the appropriate safety decision (Safe or Dangerous)
4. Provide documentation and communicate safety procedures

Table 2. Site Assessment Overview (for all tree species)

Site/Stand Factors	Hazard Indicators/Influences
Stand history and condition	<ul style="list-style-type: none"> <li>• evidence of past tree failure</li> <li>• disturbance history (natural or human-caused, including wildfire damage; age, condition and location of mechanically harvested "stubs")</li> <li>• general age, condition and density</li> <li>• tree species composition</li> <li>• evidence of root and/or stem diseases</li> </ul>
Common rain, snow and ice conditions	<ul style="list-style-type: none"> <li>• high snow or ice loading</li> <li>• high rain fall periods</li> </ul>
Flooding	<ul style="list-style-type: none"> <li>• high water table</li> <li>• evidence of water damaged/decayed roots</li> <li>• area prone to flooding</li> </ul>
Windthrow potential	<ul style="list-style-type: none"> <li>• topography</li> <li>• prevailing winds</li> <li>• evidence of significant windthrow</li> <li>• area of high or recent exposure</li> <li>• stems with height/diameter ratio &gt;100 (i.e., very tall, slender stems)</li> <li>• saturated soils</li> <li>• shallow soils</li> <li>• restricted rooting depth</li> <li>• fine textured soils</li> </ul>
Crown condition	<ul style="list-style-type: none"> <li>• stress cone crop</li> <li>• thinning foliage</li> <li>• chlorosis</li> <li>• rounded crown</li> <li>• small live crown (&lt;20% of tree height)</li> </ul>
Resinosis	<ul style="list-style-type: none"> <li>• higher than normal stem or basal pitch flow</li> </ul>
Tree lean	<ul style="list-style-type: none"> <li>• trees recently leaning due to windstorm, root damage, shifting root mat or other causes</li> </ul>
Additional site-specific factors	<ul style="list-style-type: none"> <li>• based on local knowledge (e.g., soil or slope instability)</li> </ul>

Table 3. *Danger Tree Assessment Process for Level 1 Disturbance Activities – Significant Hazard Indicators*

<b>D = Dangerous</b>	<p><b>D if tree has one or more of the following significant tree hazard indicators that are at risk of imminent failure:</b></p> <ul style="list-style-type: none"> <li>• <b>Insecurely lodged trees or insecure hang-ups:</b> <ol style="list-style-type: none"> <li>i) Insecurely lodged trees (a tipped tree that is likely to shake free of the support trees and fall to the ground); or</li> <li>ii) Dislodged but hung-up limbs or tops (consider size and height above ground) at risk of shifting free during light winds or other tree motion</li> </ol> </li> <li>• <b>highly unstable tree:</b> Examples:           <ol style="list-style-type: none"> <li>i) &gt;50% tree cross-sectional area damaged or decayed; or</li> <li>ii) Spongy snags with heart rot conks along the majority of the length of the stem (e.g., class 5-6 conifers or class 4 deciduous) or soft snags (e.g., class 7-8 conifers or class 5 deciduous); or</li> <li>iii) &gt;50% lateral roots damaged or with advanced decay</li> </ol> </li> <li>• <b>recent lean</b> toward work area AND decayed root system (&gt;50% of roots have advanced decay) or damaged and lifting anchoring soil layer (consider soil conditions and anchoring)</li> </ul>
<b>S = safe</b>	all other trees

### Wildlife Tree Value Rating

Wildlife Tree Value	Characteristics
<p style="text-align: center;">HIGH</p> <p>a high value tree has at least two of the characteristics listed in the adjacent column and, where possible, is within the upper 10–15% of the diameter range distribution for the site</p>	<ul style="list-style-type: none"> <li>• internal decay (heartrot or natural/excavated cavities present)</li> <li>• a sound, firm stem shell</li> <li>• crevices present (loose bark or cracks suitable for bats)</li> <li>• large brooms present</li> <li>• active or recent wildlife use (feeding, nesting, denning)</li> <li>• tree structure suitable for wildlife use (suitable for large nest, hunting perch sites, bear den, etc.)</li> <li>• largest trees for site (height and/or diameter) and veteran trees</li> <li>• locally important wildlife tree species</li> <li>• favourably located for use by wildlife</li> </ul>
<p style="text-align: center;">MEDIUM</p>	<ul style="list-style-type: none"> <li>• large, stable trees that will likely develop two or more of the above attributes</li> </ul>
<p style="text-align: center;">LOW</p>	<ul style="list-style-type: none"> <li>• trees not covered by high or medium categories</li> </ul>

Note: Under section 34 of the *Wildlife Act*, no tree with an active nest or the nest of an eagle, peregrine falcon, gyrfalcon, osprey, heron or burrowing owl can be disturbed.

**Wildlife Tree Uses** The following codes can be used to document the types of recent uses observed:

CN – Cavity Nest      ON – Open nest      F – Feeding      M – Mark tree      D – Denning      P – Perching

**Table 4. Dangerous Tree Criteria for Level 2 Disturbance Activities**

**NOTE:** Any tree defects as described in the boxes below will be rated as **DANGEROUS** for level 2 disturbance. Trees with lesser defects can be rated **SAFE** for level 2 – take care to not brush trees and to fall and yard away if possible.

Defect Category	Species Group	
	Douglas-fir, larch, pines, spruces	Western redcedar, yellow cedar
<b>Hazardous top (HT)</b>	<ul style="list-style-type: none"> <li>• <b>Class 2 to 5 trees:</b> Defective top (any size; e.g., secondary top) where <b>structural weakness is evident; OR</b></li> <li>• <b>Class 4 and 5 trees:</b> Defective top (e.g., secondary top) &gt;30% of tree height</li> </ul>	<ul style="list-style-type: none"> <li>• <b>Class 2 to 5 trees:</b> Defective top (any size; e.g., secondary top) where <b>structural weakness is evident</b></li> </ul>
<b>Dead limbs (DL)</b>	<ul style="list-style-type: none"> <li>• Dead limbs &gt;10 cm diameter with <b>structural weakness</b></li> <li>• Hung-up limbs</li> </ul>	<ul style="list-style-type: none"> <li>• Dead limbs &gt;15 cm diameter with <b>structural weakness</b></li> <li>• Hung-up limbs</li> </ul>
<b>Witches' broom (WB)</b>	Brooms >1 m diameter on dead branches with evidence of decay, cracking or failure (dead branches and brooms may be on the ground)	n/a
<b>Split trunk (ST)</b> (includes frost, lightning, wind- and impact-induced cracks)	Crack or split >2 cm wide extending >25% of tree diameter into stem <b>AND</b> evidence of advanced decay in surrounding stemwood	Crack or split >2 cm wide extending >50% of tree diameter into stem <b>AND</b> evidence of advanced decay in surrounding stemwood
<b>Stem damage (SD)</b> (includes scarring, fire, machine, and animal damage or butt rot)	>25% of tree cross-sectional area damaged, burned, scarred or fractured	>50% of tree cross-sectional area damaged, burned, scarred or fractured
<b>Thick sloughing bark or sloughing sapwood (SB)</b> (bark applicable to Douglas-fir, larch and ponderosa pine)	<b>Class 6–8 trees:</b> Large pieces of bark or sapwood separated and sloughing from bole of tree*	<ul style="list-style-type: none"> <li>• Bark n/a</li> <li>• Long slabs of sloughing sapwood hanging from bole of tree</li> </ul>
<b>Butt and stem cankers (CA)</b>	>50% of butt or stem circumference as a perennial canker face	n/a
<b>Fungal fruiting bodies (CM)**</b> (conks and mushrooms)	<ul style="list-style-type: none"> <li>• <b>Any heartrot fungus present</b></li> <li><b>Exception:</b> For veteran and dominant trees, if <i>Phellinus pini</i> conks present <b>BUT NO</b> other visible defects/damage to stem that allow oxygen exchange (e.g., broken top, scarring, nest cavity, etc.) = <b>SAFE</b>;</li> <li>• Sap-rotting fungi present on any tree &lt;30 cm dbh where saprot depth is &gt;5 cm</li> </ul>	n/a
<b>Tree lean (TL)</b> (for class 1–3 trees)	Lean >15% toward target/work area AND tree has rooting problems (e.g., damaged roots; shallow, compacted or wet soils; cracked or lifting root mat; steep slope)	Lean >15% toward target/work area AND tree has rooting problems (e.g., damaged roots; shallow, compacted or wet soils; cracked or lifting root mat; steep slope)
<b>Tree lean (TL)</b> (for class 4–8 trees)	Lean >10% toward target/work area AND tree has rooting problems (e.g., damaged roots; shallow, compacted or wet soils; cracked or lifting root mat; steep slope)	Lean >10% toward target/work area AND tree has rooting problems (e.g., damaged roots; shallow, compacted or wet soils; cracked or lifting root mat; steep slope)
<b>Root inspection (RI)</b>	Occurrence of any of the following: root pull; lifting root mat; visible decay or damage to roots affects >50% of lateral roots	Occurrence of any of the following: root pull; lifting root mat; visible decay or damage to roots affects >50% of lateral roots
<b>Average stemwood shell thickness</b> (for Detailed Tree Assess.)	Average sound stemwood shell thickness <30% of tree radius	Average sound stemwood shell thickness <30% of tree radius

(continued)

**NOTE:** Structural weakness includes decay, cracking, breakage, embedded bark or cracking at forks or multiple stem unions, presence of conks, stem scars, and woodpecker cavities.

\* In Douglas-fir and ponderosa pine, treat sloughing sapwood according to the bark failure potential criteria.

\*\* If identity of wood decay fungus cannot be determined (e.g., saprot or heartrot), then default to Dangerous rating. Where *Phellinus pini* is present, if the stem has structural damage such as a broken top or scarring which allow oxygen exchange or other stress indicators (e.g., resinosis, damaged roots), **OR** if there are conks distributed along the bole length, then default to Dangerous rating.

**Table 4. Dangerous Tree Criteria for Level 2 Disturbance Activities**

**NOTE:** Any tree defects as described in the boxes below will be rated as **DANGEROUS** for level 2 disturbance. Trees with lesser defects can be rated **SAFE** for level 2 – take care to not brush trees and to fall and yard away if possible.

Defect Category	Species Group	
	Hemlock, true firs	Broad-leaved deciduous
<b>Hazardous top (HT)</b>	<ul style="list-style-type: none"> <li>• <b>Class 2 to 5 trees:</b> Defective top (any size; e.g., secondary top) where structural weakness is evident; OR</li> <li>• <b>Class 4 and 5 trees:</b> Defective top (e.g., secondary top) &gt;20% of tree height</li> </ul>	<ul style="list-style-type: none"> <li>• <b>Class 2 to 5 trees:</b> Top (any size) as a fork, co-dominant or multiple stem where <b>structural weakness is evident; OR</b></li> <li>• Where a dead top is &gt;20% of the tree height</li> </ul>
<b>Dead limbs (DL)</b>	<ul style="list-style-type: none"> <li>• Dead limbs &gt;10 cm diameter with <b>structural weakness</b></li> <li>• Hung-up limbs</li> </ul>	<ul style="list-style-type: none"> <li>• Dead limbs &gt;10 cm diameter (including "scaffold branching") with <b>structural weakness</b></li> <li>• Hung-up limbs</li> </ul>
<b>Witches' broom (WB)</b>	Brooms >1 m diameter on dead branches with evidence of decay, cracking or failure (dead branches and brooms may be on the ground)	n/a
<b>Split trunk (ST)</b> (includes frost, lightning, wind- and impact-induced cracks)	Crack or split >2 cm wide extending >25% of tree diameter into stem <b>AND</b> evidence of advanced decay in surrounding stemwood	Crack or split >2 cm wide extending >25% of tree diameter into stem <b>AND</b> evidence of advanced decay in surrounding stemwood
<b>Stem damage (SD)</b> (includes scarring, fire, machine, and animal damage or butt rot)	>25% of tree cross-sectional area damaged, burned, scarred or fractured	>25% of tree cross-sectional area damaged, burned, scarred or fractured
<b>Thick sloughing bark or sloughing sapwood (SB)</b> (bark applicable to cottonwood >50 cm dbh)	n/a	<b>Class 5 trees:</b> Large pieces of bark separated and sloughing from bole of tree
<b>Butt and stem cankers (CA)</b>	n/a	>50% of butt or stem circumference as a canker face on a dead tree
<b>Fungal fruiting bodies (CM)</b> * (conks and mushrooms)	<ul style="list-style-type: none"> <li>• <b>Any heartrot fungus present</b></li> <li>• Sap-rotting fungi present on any tree &lt;30 cm dbh where saprot depth is &gt;5 cm</li> </ul>	<ul style="list-style-type: none"> <li>• <b>Any heartrot fungus present</b></li> <li><b>Exception:</b> <i>P. tremulae</i> on live trembling aspen; apply alternate safe work procedures;</li> <li>• Sap-rotting fungi present on any trees &lt;30 cm dbh where saprot depth is &gt;5 cm</li> </ul>
<b>Tree lean (TL)</b> (for class 1–3 trees)	Lean >15% toward target/work area <b>AND</b> tree has rooting problems (e.g., damaged roots; shallow, compacted or wet soils; cracked or lifting root mat; steep slope)	Lean >15% toward target/work area <b>AND</b> tree has rooting problems (e.g., damaged roots; shallow, compacted or wet soils; cracked or lifting root mat; steep slope)
<b>Tree lean (TL)</b> (for class 4–8 trees)	Lean >10% toward target/work area <b>AND</b> tree has rooting problems (e.g., damaged roots; shallow, compacted or wet soils; cracked or lifting root mat; steep slope)	Lean >10% toward target/work area <b>AND</b> tree has rooting problems (e.g., damaged roots; shallow, compacted or wet soils; cracked or lifting root mat; steep slope)
<b>Root inspection (RI)</b>	Occurrence of any of the following: root pull; lifting root mat; visible decay or damage to roots affects >50% of lateral roots	Occurrence of any of the following; root pull; lifting root mat; visible decay or damage to roots affects >50% of lateral roots
<b>Average stemwood shell thickness</b> (for Detailed Tree Assess.)	Average sound stemwood shell thickness <30% of tree radius	Average sound stemwood shell thickness <30% of tree radius

**NOTE:** Structural weakness includes decay, cracking, breakage, embedded bark or cracking at forks or multiple stem unions, presence of conks, stem scars, and woodpecker cavities.

\* If identity of wood decay fungus cannot be determined (e.g., saprot or heartrot), then default to Dangerous rating.

**Table 4a. Dangerous Tree Criteria for Level 3 Disturbance Activities**

**NOTE:** Any tree defects as described in the boxes below will be rated as **DANGEROUS** for level 3 disturbance. Trees with lesser defects can be rated **SAFE** for level 3 – take care to not brush trees and to fall and yard away if possible.

Defect Category	Species Group	
	Douglas-fir, larch, pines, spruces	Western redcedar, yellow cedar
<b>Hazardous top (HT)</b>	<ul style="list-style-type: none"> <li>• <b>Class 2 to 5 trees:</b> Defective top (any size; e.g., secondary top) where structural weakness is evident; OR</li> <li>• <b>Class 4 and 5 trees:</b> Defective top (e.g., secondary top) &gt;30% of tree height</li> </ul>	<ul style="list-style-type: none"> <li>• <b>Class 2 to 5 trees:</b> Defective top (any size; e.g., secondary top) where structural weakness is evident</li> </ul>
<b>Dead limbs (DL)</b>	<ul style="list-style-type: none"> <li>• Dead limbs &gt;10 cm diameter with structural weakness</li> <li>• Cracked, decayed, broken or hung-up limbs</li> </ul>	<ul style="list-style-type: none"> <li>• Dead limbs &gt;15 cm diameter with structural weakness</li> <li>• Cracked, decayed, broken or hung-up limbs</li> </ul>
<b>Witches' broom (WB)</b>	Brooms >1 m diameter on live or dead branches AND evidence of decay, cracking or failure	n/a
<b>Split trunk (ST)</b> (includes frost, lightning, wind- and impact-induced cracks)	Crack or split >2 cm wide extending >25% of tree diameter into stem AND evidence of advanced decay in surrounding stemwood	<ul style="list-style-type: none"> <li>• <b>Class 2 and 3 trees:</b> Crack or split &gt;2 cm wide extending &gt;50% of tree diameter into stem AND evidence of decay in surrounding stemwood</li> <li>• <b>Class 4–8 trees:</b> Crack or split &gt;2 cm wide extending &gt;25% of tree diameter into stem AND evidence of decay in surrounding stemwood</li> </ul>
<b>Stem damage (SD)</b> (includes scarring, fire, machine, and animal damage or butt rot)	>25% of tree cross-sectional area damaged, burned, scarred or fractured	<ul style="list-style-type: none"> <li>• <b>Class 2 and 3 trees:</b> &gt;50% of tree cross-sectional area damaged, burned, scarred or fractured</li> <li>• <b>Class 4–8 trees:</b> &gt;25% of tree cross-sectional area damaged, burned, scarred or fractured</li> </ul>
<b>Thick sloughing bark or sloughing sapwood (SB)</b> (bark applicable to Douglas-fir, larch and ponderosa pine)	Large pieces of bark or sapwood separated and sloughing from bole of tree	<ul style="list-style-type: none"> <li>• Bark n/a</li> <li>• Long slabs of sapwood hanging from bole of tree</li> </ul>
<b>Butt and stem cankers (CA)</b>	>50% of butt or stem circumference as a perennial canker face*	n/a
<b>Fungal fruiting bodies (CM)**</b> (conks and mushrooms)	<ul style="list-style-type: none"> <li>• <b>Any heartrot fungus present</b></li> <li>• <b>Exception:</b> For veteran and dominant trees, if <i>Phellinus pini</i> conks present BUT NO other visible defects/damage to stem that allow oxygen exchange (e.g., broken top, scarring, nest cavity, etc.) = SAFE;</li> <li>• Sap-rotting fungi present on any tree &lt;30 cm dbh where saprot depth is &gt;3 cm</li> </ul>	n/a
<b>Tree lean (TL)</b> (for class 1–3 trees)	Lean >15% toward target/work area AND tree has rooting problems (e.g., damaged roots; shallow, compacted or wet soils; cracked or lifting root mat; steep slope)	<ul style="list-style-type: none"> <li>• Lean &gt;15% toward target/work area AND tree has rooting problems (e.g., damaged roots; shallow, compacted or wet soils; cracked or lifting root mat; steep slope)</li> <li>• For candelabra-branched trees, where candelabras are predominantly on lean side of tree—lean &gt;10% toward target/work area and tree has rooting problems</li> </ul>
<b>Tree lean (TL)</b> (for class 4–8 trees)	Lean >10% toward target/work area AND tree has rooting problems (e.g., damaged roots; shallow, compacted or wet soils; cracked or lifting root mat; steep slope)	Lean >10% toward target/work area AND tree has rooting problems (e.g., damaged roots; shallow, compacted or wet soils; cracked or lifting root mat; steep slope)
<b>Root inspection (RI)</b>	Occurrence of any of the following: root pull; lifting root mat; visible damage or decay to roots affects >25% of lateral roots	Occurrence of any of the following; root pull; lifting root mat; visible damage or decay to roots affects >25% of lateral roots
<b>Average stemwood shell thickness</b> (for Detailed Tree Assess.)	Average sound stemwood shell thickness <30% of tree radius	Average sound stemwood shell thickness <30% of tree radius

(continued)

**NOTE:** Structural weakness includes decay, cracking, breakage, embedded bark or cracking at forks or multiple stem unions, presence of conks, stem scars, and woodpecker cavities.

\*/\*\* Footnotes can be found on page 8 (on reverse).

**Table 4a. Dangerous Tree Criteria for Level 3 Disturbance Activities (concluded)**

**NOTE:** Any tree defects as described in the boxes below will be rated as **DANGEROUS** for level 3 disturbance. Trees with lesser defects can be rated **SAFE** for level 3 – take care to not brush trees and to fall and yard away if possible.

Defect Category	Species Group	
	Hemlock, true firs	Broad-leaved deciduous
<b>Hazardous top (HT)</b>	<ul style="list-style-type: none"> <li>• <b>Class 2 to 5 trees:</b> Defective top (any size; e.g., secondary top) <b>where structural weakness is evident; OR</b></li> <li>• <b>Class 4 and 5 trees:</b> Defective top (e.g., secondary top) &gt;20% of tree height</li> </ul>	<ul style="list-style-type: none"> <li>• <b>Class 2 to 5 trees:</b> Defective top (any size) in the form of a fork, co-dominant or multiple stem <b>where structural weakness is evident; OR</b></li> <li>• Where dead top &gt;20% of tree height</li> </ul>
<b>Dead limbs (DL)</b>	<ul style="list-style-type: none"> <li>• Dead limbs &gt;10 cm diameter <b>with structural weakness</b></li> <li>• Cracked, decayed, broken or hung-up limbs</li> </ul>	<ul style="list-style-type: none"> <li>• Dead limbs &gt;10 cm diameter <b>with structural weakness</b></li> <li>• Cracked, decayed, broken or hung-up limbs</li> </ul>
<b>Witches' broom (WB)</b>	Brooms >1 m diameter on live or dead branches AND evidence of decay, cracking or failure	n/a
<b>Split trunk (ST)</b> (includes frost, lightning, wind- and impact-induced cracks)	Crack or split >2 cm wide extending >25% of tree diameter into stem <b>AND</b> evidence of advanced decay in surrounding stemwood	Crack or split >2 cm wide extending >25% of tree diameter into stem <b>AND</b> evidence of decay in surrounding stemwood
<b>Stem damage (SD)</b> (includes scarring, fire, machine, and animal damage or butt rot)	>25% of tree cross-sectional area damaged, burned, scarred or fractured	>25% of tree cross-sectional area damaged, burned, scarred or fractured
<b>Thick sloughing bark or sloughing sapwood (SB)</b> (bark applicable to cottonwood >50 cm dbh)	n/a	Large pieces of bark separated and sloughing from bole of tree
<b>Butt and stem cankers (CA)</b>	n/a	<ul style="list-style-type: none"> <li>• &gt;20% of butt or stem circumference as a perennial canker face*</li> <li>• &gt;50% of butt or stem circumference as a canker face on a dead tree</li> </ul>
<b>Fungal fruiting bodies (CM)**</b> (conks and mushrooms)	<ul style="list-style-type: none"> <li>• <b>Any heartrot fungus present; OR</b></li> <li>• Sap-rotting fungi present on any tree &lt;60 cm dbh where saprot depth is &gt;6 cm</li> </ul>	<ul style="list-style-type: none"> <li>• <b>Any heartrot fungi present</b></li> <li>• <b>Exception:</b> <i>P. tremulae</i> on live trembling aspen; apply alternate safe work procedures;</li> <li>• Sap-rotting fungi present on trees &lt;60 cm dbh where saprot depth is &gt;6 cm</li> </ul>
<b>Tree lean (TL)</b> (for class 1–3 trees)	Lean >15% toward target/work area AND tree has rooting problems (e.g., damaged roots; shallow, compacted or wet soils; cracked or lifting root mat; steep slope)	Lean >15% toward target/work area AND tree has rooting problems (e.g., damaged roots; shallow, compacted or wet soils; cracked or lifting root mat; steep slope)
<b>Tree lean (TL)</b> (for class 4–8 trees)	Lean >10% toward target/work area AND tree has rooting problems (e.g., damaged roots; shallow, compacted or wet soils; cracked or lifting root mat; steep slope)	Lean >10% toward target/work area AND tree has rooting problems (e.g., damaged roots; shallow, compacted or wet soils; cracked or lifting root mat; steep slope)
<b>Root inspection (RI)</b>	Occurrence of any of the following: root pull; lifting root mat; visible damage or decay to roots affects >25% of lateral roots	Occurrence of any of the following; root pull; lifting root mat; visible damage or decay to roots affects >25% of lateral roots
<b>Average stemwood shell thickness</b> (for Detailed Tree Assessment)	Average sound stemwood shell thickness <30% of tree radius	Average sound stemwood shell thickness <30% of tree radius

**NOTE:** Structural weakness includes decay, cracking, breakage, embedded bark or cracking at forks or multiple stem unions, presence of conks, stem scars, and woodpecker cavities.

\* Perennial cankers are generally circular to lens-shaped cankers that can persist for years, and slowly expand at about the same rate as the radial growth of the affected live tree. They gradually take on a sunken appearance as tissues under the dead cambium do not grow along with the surrounding wood. They are sometimes called "exploding cankers."

\*\* If identity of wood decay fungus cannot be determined (e.g., saprot or heartrot), then default to Dangerous rating. Where *Phellinus pini* is present on Douglas-fir, larch, pines and spruces, if the stem has structural damage such as a broken top or scarring which allow oxygen exchange or other stress indicators (e.g., resinosis, damaged roots), **OR** if there are conks distributed along the bole length, then default to Dangerous rating.



**Table 5. Danger Tree Assessment Process for Level 4 Disturbance Activities**

When conducting Level 4 disturbance assessments, only the following four types of trees are rated safe. All other trees will be rated Dangerous for Level 4 activities.

<p>Level 4 Disturbance</p> <p><b>S = Safe</b> if tree is one of the following:</p> <ul style="list-style-type: none"> <li>• class 1 tree (all species)</li> <li>• class 2 trees with NO structural defects (all species) (usually wind- or snow-snapped green trees, very light fire scorching).</li> <li>• class 2 cedars with LOW failure potential defects (refer to table below)</li> <li>• class 3 conifers with NO structural defects (tree recently killed by insects, climate or light intensity fire—these will have no structural damage or decay)</li> </ul> <p><b>D = Dangerous</b> all other trees (fall tree; create a no-work zone; or remove hazardous parts)</p>
<p>NOTE: Any leave tree that is damaged during the work activity must be reassessed if work is to continue within reach</p>

Class 2 Cedar Trees Are Safe for LOD4 if They Fit the Following Criteria:

Defect Category	Western redcedar, yellow cedar Low Failure Potential
<b>Hazardous top (HT)</b>	Defective top (e.g. secondary top, spike) <30% of tree height with <b>no evidence</b> of decay, cracking, failure or other structural weakness
<b>Dead limbs (DL)</b>	Dead limbs (no size limit) with <b>no evidence</b> of decay, cracking or failure
<b>Split trunk (ST)</b> (includes frost, lightning and wind-induced cracks; does not include dry checking)	Crack or split >2 cm wide extending <50% of tree diameter into stem; <b>no evidence</b> of decay in surrounding stemwood
<b>Stem damage (SD)</b> (includes scarring, fire damage, machine damage, animal damage or butt rot)	<50% of tree cross-sectional area damaged, scarred or fractured with <b>no evidence</b> of decay in remaining stemwood
<b>Tree lean (TL)</b>	Lean <30% (16°) toward target/work area and tree has no rooting problems
<b>Lean (TL) — candelabra branched trees</b> (where candelabras are predominantly on lean side of tree)	Lean <10% (5°) toward target/work area and tree has no rooting problems
<b>Root inspection (RI)</b>	<b>No visible problems:</b> no root pull or lifting root mat. Any visible structural damage to roots only affects <25% of lateral roots (remaining roots undamaged)
<b>Average stemwood shell thickness</b> (for Detailed Tree Assessment)	Total sound stemwood shell thickness >30% of tree radius

---

## Tree Lean Comparisons

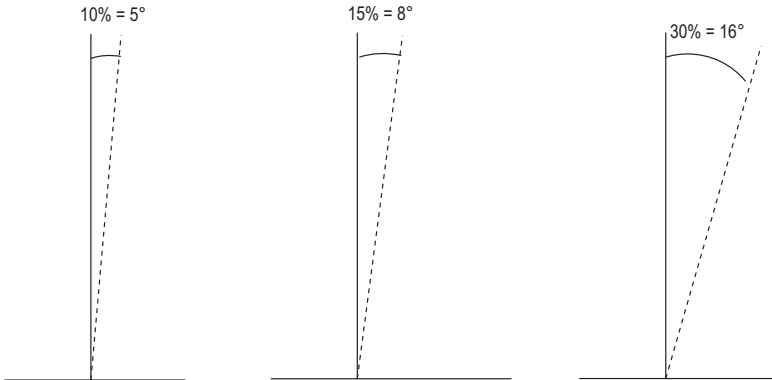









---

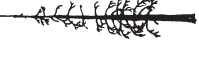



### Safety Procedures (for "suspect" trees that have been assessed)

- S**
  - tree safe to work around, retain tree—no removal or modification necessary
  - mark tree as **Safe** (tag, paint or flagging as appropriate)
  - monitor tree if appropriate
- D**
  - remove tree
  - remove dangerous part(s) of tree
  - install flagged no-work zone (hazard area)
  - mark tree as **Dangerous** (tag, paint or flagging) if marking is required for work activity or site
  - inform workers of location of no-work zones (hazard area) and trees marked as **Dangerous**.

# Decay Class Comparison for Conifers and Hardwoods

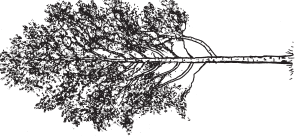
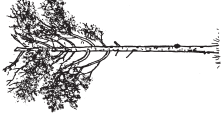
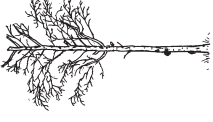
Decay class	LIVE			DEAD					DEAD FALLEN
	1	2	3	4	5	6	7	8	9
									

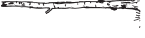
\* This classification system does not recognize root disease trees specifically. Such trees become unstable at or before death.

Decay class	LIVE			DEAD		DEAD FALLEN
	1	2	3	4	5	6
						

# NOTES

---