



United States
Department of
Agriculture

Forest Service

Pacific Northwest
Research Station

Research Note
PNW-RN-483

November 1988



New Method for Measuring Water Seepage Through Salmon Spawning Gravel

Richard D. Orchard

Abstract

A new method, with heat as a tracer, was developed for measuring rate and direction of intragravel waterflow through salmon spawning gravel. A commercial flowmeter was calibrated in the laboratory under controlled environmental conditions. Flow measurements comparing the flowmeter with a dye-tracer method were made in an artificial stream channel at Young Bay and in two low-gradient streams at Trap Bay in southeast Alaska.

The method requires a standpipe. Once the standpipe is in place, a flow reading can be taken in 3 to 5 minutes. The flowmeter response is linear for flow rates up to 150 centimeters per hour and then becomes curvilinear. A correction factor applied to the instrument response can extend the range to about 500 centimeters per hour. The flowmeter demonstrated excellent reproducibility in the laboratory. The equipment is self-contained, and all necessary supplies are available on the open market.

Keywords: Spawning habitat, flow equipment, streams, intragravel waterflow, groundwater, flowmeter.

Introduction

The rate of water seepage through salmon spawning gravel and the dissolved oxygen content of this water influence the survival of incubating embryos and the quality of resulting fry. Dissolved oxygen is a biological requirement for embryo development, and intragravel waterflow transports dissolved oxygen to the embryo and removes metabolic waste from the surroundings (Cordone and Kelley 1961). Separating the effects of these two parameters on embryo development is difficult because they interact. Very little information has been published on intragravel waterflow in natural stream systems. Most published data have been from studies conducted in the laboratory with permeameters, packed glass columns, or from artificial channels, all of which deal principally with permeability instead of direct flow-rate measurements.

RICHARD D. ORCHARD is a biological laboratory technician,
Forestry Sciences Laboratory, P.O. Box 20909, Juneau, Alaska 99802.

The equipment and method described here will allow waterflow in natural stream systems to be measured quickly and easily, once standpipes are in place. Until now, essentially three methods were used to measure intragravel waterflow in natural stream systems. Each method required a tracer and was time consuming to use. Before discussing two methods of measuring intragravel waterflow that were compared in this study, I will review these three methods and also a method in development.

Dye-Tracer Method

This method has limited use for measuring seepage through salmon spawning gravel but has been used extensively for measuring surface flow in streams, canals, drainage ditches, and sewers. Dye is injected into the stream gravel at point "A," and the time until the dye appears at point "B" is measured. Usually a standpipe is installed downstream, where water samples are periodically taken and visually inspected for dye; where the dye is not visible, a turbidity meter or fluorometer is used to detect it. Sometimes water is pumped directly from the standpipe to the detection device, providing for continuous monitoring. The flow of dye from the injection point is not necessarily dispersed over a large area of the streambed, neither vertically nor laterally. At times, discrete channels of flow do not carry water directly downstream; therefore, only by chance does a sampling point intercept the through-flow channel. Moreover, this is not a practical method of measuring intragravel waterflow when many measurements are required.

Dye-Dilution Method

This method, developed by Wickett (1954) and later modified by Pollard (1955) and Terhune (1958), is the most extensively used method of the three, and yet only about a dozen publications report on its use for measuring intragravel waterflow in natural stream systems. Determining the total number of samples taken in these studies is difficult; however, I estimated the total number of sites to be about 100, representing a total of about 400 actual flow determinations. About 70 percent of those measurements were taken at shallow depths (8-20 centimeters) in freshwater systems during a study of various species of trout. This represents very few measurements for the 30-year span since the method was developed. This method is too time consuming to be a practical means of measuring intragravel waterflow in studies in which large numbers of flow determinations are to be made.

In this method, a perforated standpipe is driven or placed in the streambed; dye is put into the standpipe, and samples are withdrawn at timed intervals. The samples are visually compared with a set of standards of known dye concentrations to determine the dilution rate. The apparent velocity is computed from a calibration curve showing the relation between known velocities and dilution rates for specific types or sizes of stream gravel.

Salt-Dilution Method

This method is described by Gangmark and Bakkala (1958). To my knowledge, these authors have been the only users of the salt-dilution method in a natural stream system. The principle of operation is essentially the same as for the dye-dilution method. A perforated standpipe is driven into the streambed. A salt solution is introduced into the standpipe, and the rate of dilution is measured with a conductivity meter.

Other Systems and Variations

Other methods and equipment, or variations of existing methods, have been used to measure flow in artificial streams or in a laboratory, with permeameters or glass columns. In the last 14 years, Pinchak (1973, 1982; Pinchak and others 1979; Pinchak and Petras 1981) has spent much time and effort in developing a self-contained, rugged, reliable, and quick method of measuring intragravel waterflow. Pinchak's system has a tiny self-heating thermistor that is placed directly into the stream gravel. The thermistor is heated above the temperature of the surrounding environment, and the flow of water past the thermistor cools it. This cooling changes the resistance of the thermistor; the change in resistance is then calibrated to the flow past the thermistor. The thermistor resistance, however, also changes with a change in the environmental temperature surrounding the thermistor; therefore, the thermistor cannot distinguish between an increase in flow and a decrease in the surrounding temperature.

Pinchak and others (1979) then developed a dual-bridge system that alternately measures flow past the sensor and the environmental temperature. This local environmental temperature information permits a correction of the velocity-bridge measurement to account for changes in the environmental temperature. Pinchak further improved the system by adding automatic electronic checks on the operation of the temperature and velocity bridge circuits. In addition, he has added a micro-computer to automatically correct for changes in the local environmental temperature and to allow rapid data acquisition and control (Pinchak and Petras 1981). Because the principle of operation requires that the thermal conductivity of the surrounding media be considered, an enormous amount of calibration is required for each thermistor probe. Although much calibration has taken place, the final product has not been assembled and still needs to be calibrated.

Study Area

Laboratory facilities were located in the Federal Building, Juneau, Alaska. Field tests were done in an artificial stream channel at Young Bay on Admiralty Island, 21 kilometers (km) southwest of Juneau and in two low-gradient streams known as Bambi and Main Stream located at Trap Bay on Chichagof Island, 72 km southwest of Juneau.

Equipment and Methods

Two methods of measuring intragravel waterflow are reported here: dye-tracer (time-in-travel) method and Geoflo¹ groundwater flowmeter method. The dye-tracer method was developed to be used as a standard of comparison for the groundwater flowmeter method. The first method is not necessarily more accurate than the second, but it provides direct evidence of flow through the intragravel environment.

¹ The use of trade, firm, or corporation names in this publication is for the information and convenience of the reader. Such use does not constitute an official endorsement or approval by the U.S. Department of Agriculture of any product or service to the exclusion of others that may be suitable.

Dye-Tracer Method

Although this method is partially described in the introduction, I provide more detail here. Stainless-steel hollow inlet and outlet probes with a 0.95-centimeter (cm) outer diameter were driven into the gravel bed to known depths (usually 36 cm) and at known distances apart. The downstream probe was 20 cm from the upstream probe if the probe could be driven into the substrate and if flow was actually observed at that point, or 15 cm from the upstream probe if the conditions for the 20-cm location could not be met. All probes were held in place and parallel to each other by a shoe (fig. 1). Dye was injected into the two upstream probes, and a timer was started. Water was pumped from the downstream probe through a 0.078-cm inner diameter (I.D.) silicone tube to a Model 111 Turner fluorometer with a microsample continuous-flow door (fig. 1). I used a potentiometric recorder to record the response of the fluorometer to the continuous flow sample. Because the chart speed and the lag time (time required to flow from stream to fluorometer) were known, distance over time could be calculated. An alarm attached to the fluorometer sounded when the response to the continuous-flow sample exceeded the background noise. Several hours were often required to obtain a single flow reading. Because of upwelling, downwelling, and lateral flow within the interstitial pore space, it is only by chance that I was able to place the dye-injection (upstream) probe and the suction (downstream) probe in the same through-flow channel. If there was no flow response after 3 or 4 hours, the attempt to take a flow reading at that site was terminated.

This method of measuring intragravel waterflow rate underestimates the actual flow rate. I used the distance between the upstream and downstream probes to calculate flow rates; however, this is the shortest distance between two points (a straight line). Water actually has to travel around, under, or over pebbles and rocks; therefore, it travels a greater distance than that used to calculate flow rates. The error would not likely be greater than twofold over such a short distance between probes. The flow is real and does in fact go from point A to point B; therefore, the method is suitable for a standard of comparison.

Geoflo Groundwater Flowmeter Method

During the summer of 1981, I used a Geoflo model 20 with an 8.9-cm diameter probe to measure intragravel waterflow. A model 30 with a 4.4-cm diameter probe was used thereafter. The operating procedure is the same for both models, and the only difference between models is the probe diameter. This method of measuring intragravel waterflow uses a flow sensor to measure rate and direction of flow inside a standpipe placed in the streambed. The manufacturer claims the flowmeter is accurate within 5 degrees for direction and within 7 percent for flow velocity for a range of 0.06 to 30.48 meters per day. Calibration of the flowmeter and selection, placement, and packing of the standpipe are important for reliable flow measurements. Following is a brief description of the flowmeter, its calibration, and the standpipe.

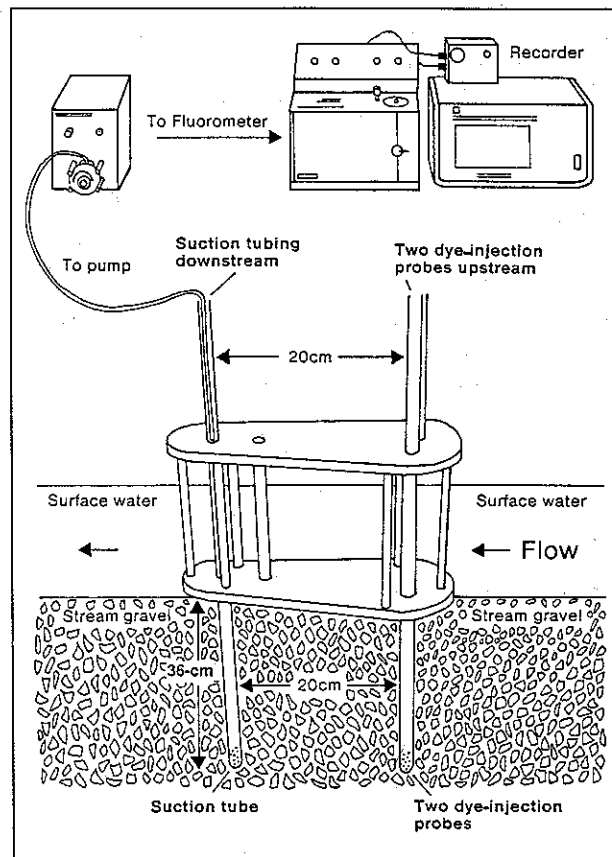

Figure 1—Equipment for measuring intragravel waterflow with the dye-tracer method.

Geoflo Groundwater Flowmeter—The groundwater flowmeter is a portable, self-contained instrument for measuring the direction and rate of very slow, lateral flow of groundwater through permeable, saturated soils (K-V Associates 1981). Its primary use thus far has been to monitor wells and provide groundwater flow information in support of hazardous waste plume tracing and spill recovery projects. The Geoflo groundwater flowmeter is described in detail in the owner's operation and maintenance manual (K-V Associates 1981). Provided with the instrument are the calibration chamber and a TI-58c calculator program for resolving the five compass vectors that determine principal flow direction.

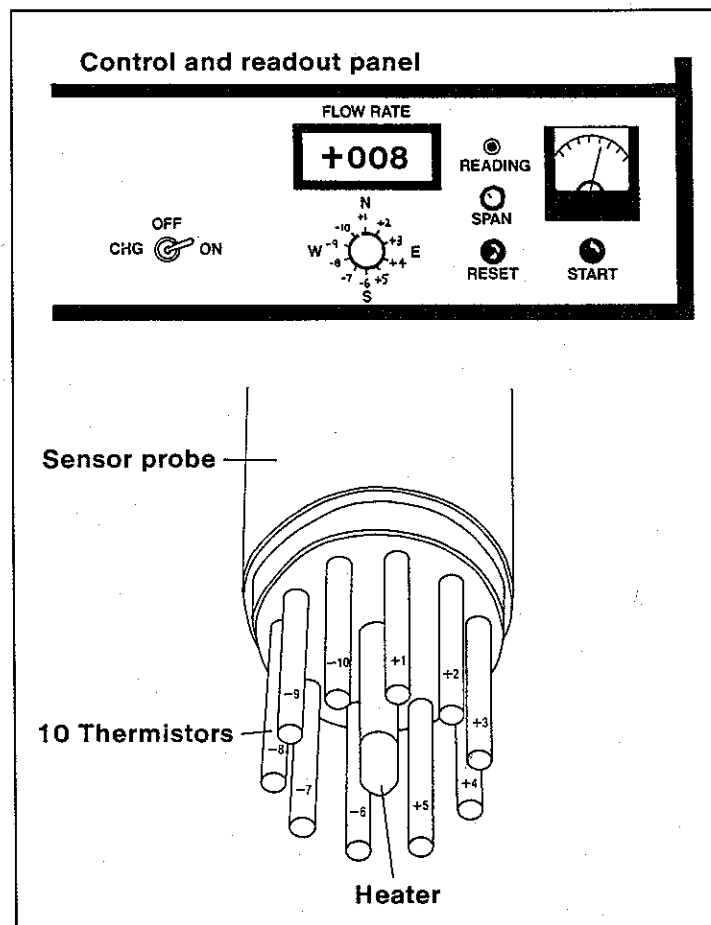

Figure 2—The probe sensor unit and the control and readout panel for the Geoflo model 30 flowmeter.

The flowmeter (fig. 2) comprises two main units: the flow sensor unit and the control and readout unit. The flow sensor unit contains a compass for directional indexing and a heat probe at the bottom center of the sensor surrounded by five pairs of diametrically opposed thermistors; that is, each thermistor within a pair is equidistant and in opposite directions from the heat probe (fig. 2). The heat probe creates a transient, short-duration, point source of heat that is transmitted through the porous soil or gravel matrix. Any net movement of the interstitial water mass creates a thermal conductance bias that is linearly proportional to the flow rate. Any thermal-conductance bias (flow) is displayed as a digital readout on the control unit display panel. The plus and minus (+,-) signs on the digital readout indicate flow direction. With the heat source in the center of a circle of thermistors, flow of water is in the direction of temperature rise in any given pair of thermistors. The 10 thermistors are arranged into two groups: group 1 through 5 and group -6 through -10. The values obtained by the thermistors in the second group are always electronically subtracted from the values obtained by their counterparts in the first group.

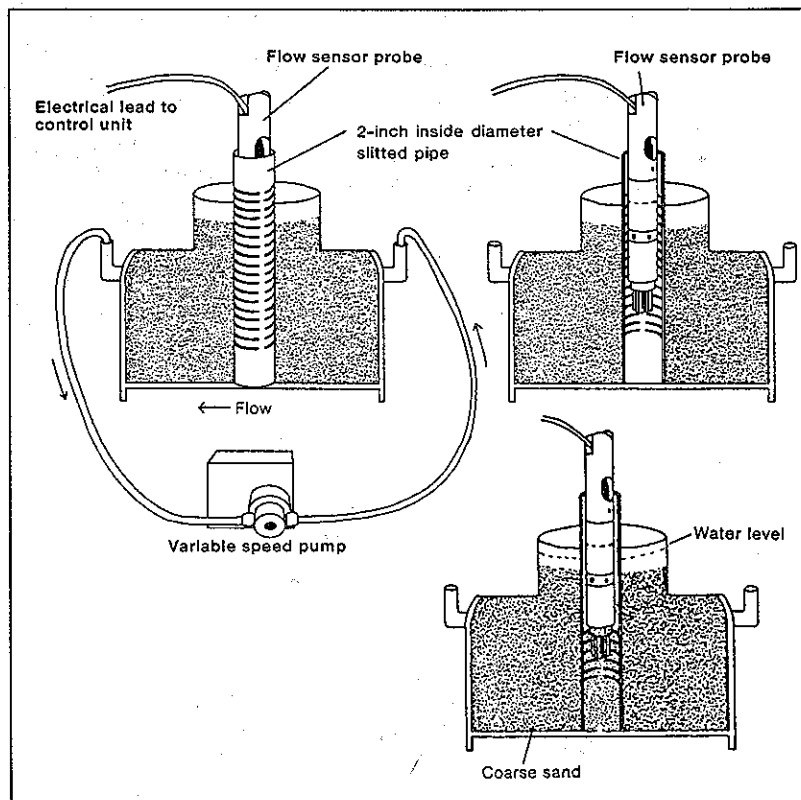

Figure 3—Calibration (flow) chamber showing placement of sorted substrate, slitted pipe, and flow sensor probe.

Calibration—The calibration chamber (fig. 3) consists of a 15.2-cm flow tube, a metered flow pump, a filter, and an inflow and outflow port. A 5.1-cm I.D. slitted polyvinyl chloride (PVC) pipe, the same as that used in the field, is inserted into the 15.2-cm flow tube. The flow tube is filled and packed with a uniform medium to coarse sand. The 5.1-cm slitted pipe is filled with and packed with the same sand as or coarser sand than that found in the surrounding substrate to a point 3.5 cm above the center line of the flow tube. This indexes the position of the thermistors to flow through the central portion of the flow tube. The permeability of the sand inside the 5.1-cm slitted pipe must be equal to or greater than the surrounding media; otherwise, waterflow past the thermistors will be restricted, forcing greater flow around the slitted pipe.

An independent laboratory analysis of the model 30 by Melville and others (1985) points out the potential problems associated with channelization around the slitted pipe. Care should also be taken in the selection of slit width in the slitted pipe and number of slits to be used. Kerfoot and Massard (1983) discuss the effect of number and width of slits on accuracy and sensitivity of groundwater flow measurements. The flow sensor probe is inserted into the 5.1-cm slitted pipe, and water is circulated at a constant rate from the outlet to the inlet of the flow tube. A span control on the readout panel of the instrument (fig. 2) allows an adjustment of the instrument's response to the velocity of water being pumped through the flow chamber. A correction factor is used for flow rates greater than 150 cm per hour.

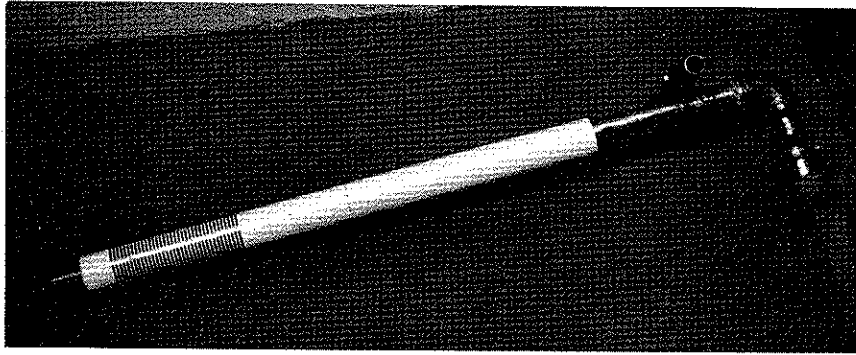

Figure 4—A hydraulic probe placed inside a slitted 5.1-centimeter inside diameter schedule 40 polyvinyl chloride (PVC) standpipe and used to work the standpipe into the stream gravel.

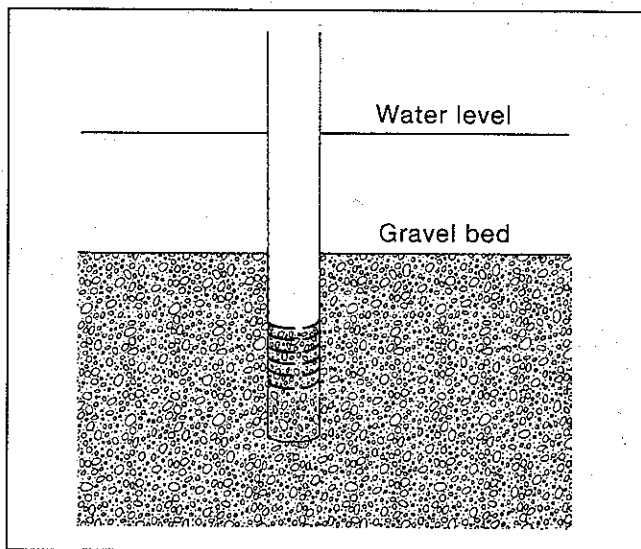

Figure 5—Standpipe placed in streambed and backfilled with sorted sand from streambed.

The time required for the instrument's response to peak is the information needed to formulate the correction factor to make the response of the flowmeter linear for flow rates of up to about 500 cm per hour. For this particular flowmeter and substrate, I defined the correction factor as 90 seconds divided by the time required for the response of the flowmeter to reach its maximum (peak) value, for each flow reading that peaked in less than 90 seconds. The correction factor, thus, will always be greater than one.

Standpipe—The standpipes are made of 5.1-cm I.D. schedule 40 PVC, with four rows of 0.26-cm slits throughout 20.3 cm of the lower section of pipe (fig. 4). The standpipes can be placed into the streambed gravel with the aid of a hydraulic sampler as described by McNeil (1964), or any device delivering enough water pressure to sufficiently displace the gravel below the standpipe to work the pipe down to a depth of about 40.6 cm. The hydraulic probe is placed through the standpipe as shown in figure 4. A high pressure stream of water from the hydraulic probe allows the probe and standpipe to be worked and forced into the streambed to the desired depth. The hydraulic probe is then slipped out of the standpipe, leaving the standpipe in place in the streambed gravel as shown in (fig. 5).

This method of standpipe placement was easy and fairly rapid once the gear was on location. The method, however, severely disturbed the sample site. The time required for the site to stabilize is not known. It was easiest to position these standpipes in a recently made redd or in the same location from which a sample of gravel had just been taken. Sorted and sized sand of known porosity was poured into the standpipe and intermittently tamped to pack the sand. This forced the sand between the pipe slits and minimized settling, thereby assuring a more constant environment. The magnitude of the effect produced by site disturbance or loose packing material is not known; therefore, as stable an environment as possible was maintained. The standpipe and sand were the same type as that used for calibration in the laboratory.

Once the standpipes were in place and stabilized, the flow-sensor probe was inserted into the sand-filled portion of the standpipe, and a flow reading was taken, which required about 3 minutes. Each flow measurement measured the flow of water through an area of about 11.3 cm^2 . About 75 readings were made on a fully charged pair of batteries.

Results and Discussion

Dye-Tracer Method

Only 55 percent of the attempts to measure intragravel water velocity actually resulted in a velocity determination with the dye-tracer method, which is why values are missing in the column under the dye-tracer method of table 1. The low success rate is because flow from the dye-injection probe traveled either below, above, or around the suction probe or the velocity was, in fact, less than the distance between probes divided by the elapsed time at termination.

Geoflo Groundwater Flowmeter Method

Initial calibration with the model 20 flowmeter demonstrated excellent reproducibility as is shown by the data points in figure 6. Extensive calibration with the model 30 flowmeter showed that two factors (temperature and size of substrate) severely affected the flowmeter's response to waterflow. As can be seen from figures 7 and 8, water temperature affects the slope of the regression line. As the water temperature is decreased, the instrument's response is increased, thereby increasing the slope of the regression line. The instrument's response also increased as the size of the substrate decreased; contrast the slopes of the regression lines of figure 7 with those of figure 8.

The temperature and substrate had an influence on flow values similar to the effect that Pinchak (1973) demonstrated with his self-heating thermistor system. The self-heating thermistor system, however, is influenced by the effect of water temperature on thermistor resistance, whereas the Geoflo system is affected by thermal differences between paired thermistors. Both systems encounter variation in thermal conductance through porous media. The variation in thermal conductance need not be a problem, however, with the Geoflo system because the substrate used to calibrate the instrument is also used for the field measurements. Calibration of the Geoflo at various temperatures within the range to be expected in the field was still needed.

The instrument response to flows greater than about 150 centimeters per hour was curvilinear (fig. 9) and required a correction factor. The time required for the instrument response to peak also varied with flow (fig. 10). All peak times greater

Table 1—Intragravel waterflow velocity at various depths on 2 low-gradient natural streams with 2 methods of measuring flow

Stream and site number	Geoflo Model 20 method depths					Dye-tracer method depths
	20.3 cm ^a	25.4 cm ^b	30.5 cm ^b	35.6 cm ^b	35.6 cm ^c	35.6 cm ^d
<i>Centimeters per hour</i>						
Bambi:						
1		6	6	6		—
2		6	7	6		—
3		6	6	6		—
4		12	7	8		12
5		12	16	13		100
Main stream:						
1	46				7	—
2	102				19	150
3	56				7	—
4	9				7	4
5	84				9	122

— = missing values because of lack of flow response after 3 or 4 hours.

^a Average of 2 replications per depth at each site.

^b Average of 3 replications per depth at each site.

^c Average of 6 replications per depth at each site.

^d No replications.

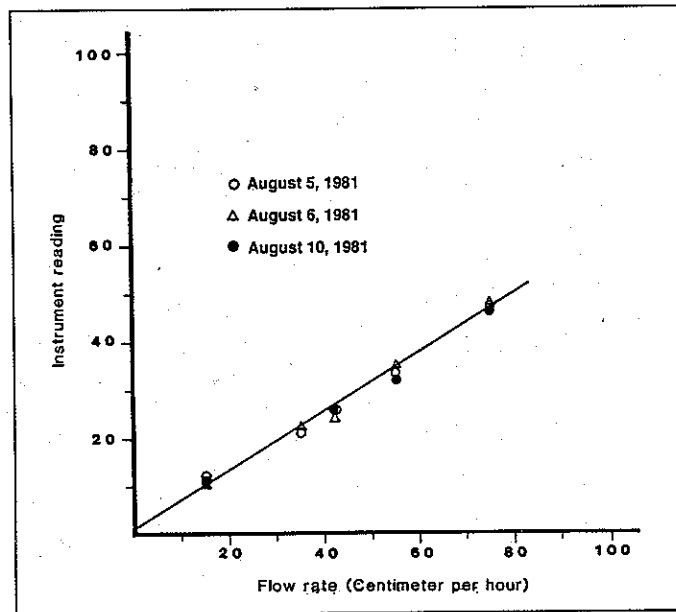

Figure 6—Plotted data points of mean flow for 3 separate days of calibration with the model 20 Geoflo groundwater flowmeter.

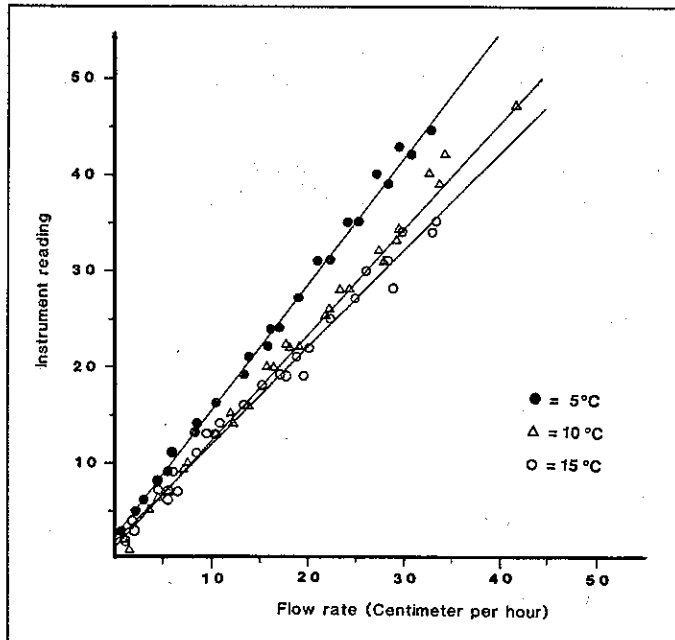

Figure 7—Flowmeter calibration curves at 5, 10, and 15° C for substrate between 1 and 2 millimeters in diameter.

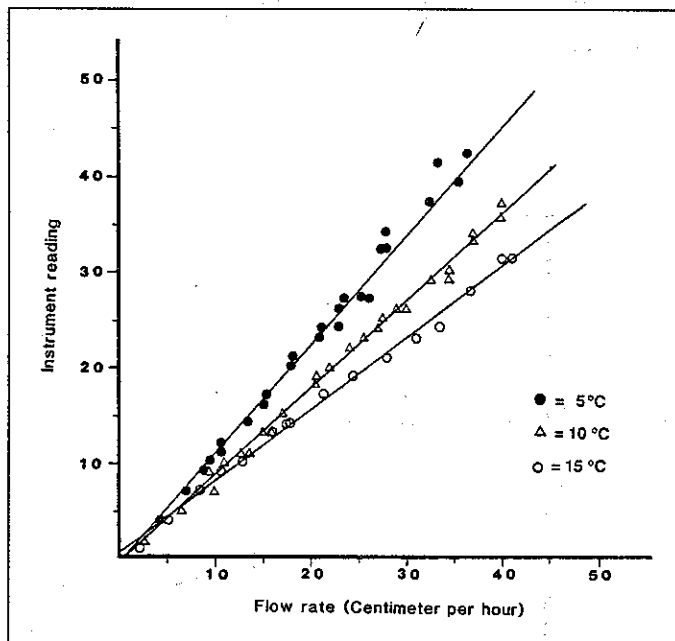

Figure 8—Flowmeter calibration curves at 5, 10, and 15° C for substrate between 2 and 3.38 millimeters in diameter.

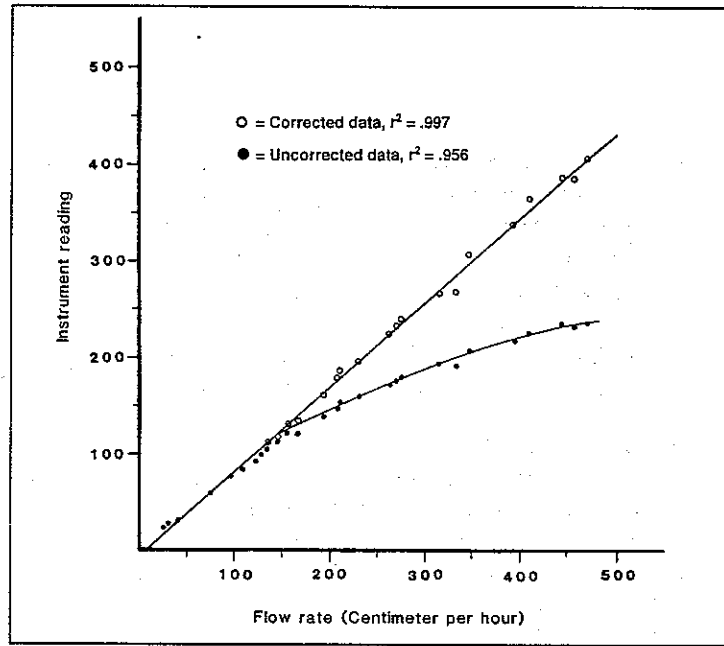

Figure 9—Corrected and uncorrected instrument response data to flow over a wide range of flow rates.

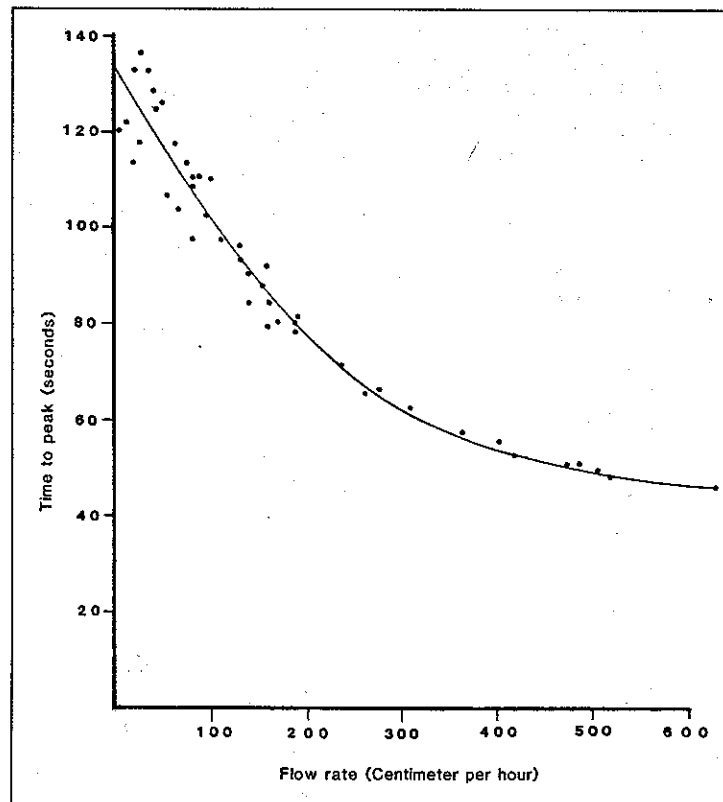

Figure 10—Plotted data points showing the time required (elapsed time) for the instrument to reach its highest (peak) value over a wide range of flow rates.

than 90 seconds and corresponding flow rates were linear, and all peak times less than 90 seconds and corresponding flow rates were curvilinear. The flowmeter reading was multiplied by the correction factor; then the corrected flowmeter reading was regressed with measured flow rate through the calibration system as shown in figure 9. The response time also varied with temperature, substrate size, and sensitivity setting. Calibration may not be necessary for high flows that require a correction, particularly in low-gradient streams. In three low-gradient streams in southeast Alaska, only 11 of 796 flow determinations required a correction.

A Comparison of Data From the Two Methods

Because there is no way to measure intragravel waterflow in precisely the same interstitial pore space with two separate methods and because the spatial variation in intragravel waterflow is quite large, comparisons between the two methods are relative. Flow measurements with the dye-tracer method were made beside the standpipes used in the Geoflo method for each site. In other words, site represents standpipe number. The flow rates as shown in table 2 varied considerably from site to site with both methods. The flow rates measured with the dye-tracer method tended to be much higher than those from the Geoflo method. The difference may have been a result of the method, the spatial variation, or the disturbance of the streambed environment. The latter was likely a major contributor. The standpipes remained in place and tended to become stabilized. The dye inlet and outlet probes, however, were driven into the streambed just before a measurement was taken; they were then removed and used again at the next site. When the values in table 1 are combined with those in table 2, a low flow value from the Geoflo method generally agreed with a low value from the dye-tracer method.

Much lower flows were measured in the natural streams (table 1) than in the artificial channel (table 2). This is not surprising because the artificial channel had a 3-percent gradient, whereas the natural streams had gradients of less than 1 percent.

Table 2—Intragravel waterflow velocity with 2 methods, the Geoflo Model 20 and the dye-tracer, in an artificial channel

Site number	Geoflo Model 20 method replications					Dye-tracer method						
	August 26, 1981				September 16, 1981					August 21-22, 1981	August 26, 1981	
	A	B	C	Mean	A	B	C	D	Mean			
<i>Centimeters per hour</i>												
1	555	542	542	546							1944	3780
2	113	119	132	121	493	446	474	425	460		767	1080
3	188	188	159	178	241	351	309	313	304		515	1944
4	319	411	401	377	713	566	549	470	575		371	612
5	77	86	80	81	59	40	30	28	39		256	936
6	76	83	83	80	330	388	311	304	333			720

Conclusion

Work continues toward developing a quick, easy, and reliable method of measuring intragravel waterflow in natural salmon spawning streams without the aid of standpipes. Until such a method becomes available, the equipment and methods described in this paper represent state-of-the-art methodology for measuring water seepage through salmon spawning gravel.

English Equivalents

1 millimeter = 0.0394 inch

1 centimeter = 0.394 inch

1 square centimeter = 0.155 square inch

1 meter = 3.281 feet or 39.37 inches

1 kilometer = 0.621 mile

1 centimeter per hour = 0.787 foot per day

References

- Cordone, Almo J.; Kelley, Don W. 1961.** The influences of inorganic sediment on the aquatic life of streams. *California Fish and Game*. 47(2): 189-228.
- Gangmark, Harold A.; Bakkala, Richard G. 1958.** Plastic standpipe for sampling streambed environment of salmon spawn. Special Scientific Report: Fisheries 261. Washington, DC: U.S. Department of the Interior, Fish and Wildlife Service. 20 p.
- Kerfoot, William B.; Massard, Victoria A. 1983.** Monitoring well influences on direct flow meter measurements. Falmouth, MA: K-V Associates, Inc. Unpublished report. 13 p.
- K-V Associates. 1981.** Groundwater flowmeter system operations and maintenance manual: model 30. Falmouth, MA: K-V Associates, Inc. 31 p.
- McNeil, William J. 1964.** A method of measuring mortality of pink salmon eggs and larvae. Auke Bay, Alaska: U.S. Department of the Interior. Fish and Wildlife Service. *Fishery Bulletin*. 63(3): 575-588.
- Melville, Joel G.; Molz, Fred J.; Guven, Oktay. 1985.** Laboratory investigation and analysis of a ground-water flowmeter. *Groundwater*. 23(4): 486-495.
- Pinchak, Alfred C. 1973.** Measurement of intragravel water velocity. Cleveland, OH: Analytical Research Associates; Final Report; Grant FS-PNW-7. Available from: U.S. Department of Agriculture, Forest Service, Pacific Northwest Research Station, Forestry Sciences Laboratory, P.O. Box 20909, Juneau, AK 99802. 45 p.
- Pinchak, Alfred C. 1982.** 1982 tests for self-heated thermistor system for the measurement of intragravel water velocity. Juneau, AK: U.S. Department of Agriculture, Forest Service, Pacific Northwest Research Station. Final Report; Project 40-0452-2-598. 46 p.
- Pinchak, Alfred C.; Petras, Emery G. 1981.** CMOS microprocessor based dual-bridge thermistor system for measurement of intragravel water flow. In: *Flow: its measurement and control in science and industry*. Research Triangle Park, NC: Instrument Society of America: 632-648 Vol. 2.

Pinchak, Alfred C.; Petras, Emery G.; Walkotten, William J. 1979. Measurement of intragravel water velocities by means of self-heated thermistors. Cleveland, OH: Analytical Research Associates; final report; Grant 54. Available from: U.S. Department of Agriculture, Forest Service, Pacific Northwest Research Station, Forestry Sciences Laboratory, P.O. Box 20909, Juneau, AK 99802. 75 p.

Pollard, R.A. 1955. Measuring seepage through salmon spawning gravel. *Journal of the Fisheries Research Board of Canada.* 12(5): 706-741.

Terhune, L.D.B. 1958. The Mark VI groundwater standpipe for measuring seepage through salmon spawning gravel. *Journal of the Fisheries Research Board of Canada.* 15(5): 1027-1063.

Wickett, Percy W. 1954. The oxygen supply of salmon eggs in spawning beds. *Journal of the Fisheries Research Board of Canada.* 11(6): 933-953.

The **Forest Service** of the U.S. Department of Agriculture is dedicated to the principle of multiple use management of the Nation's forest resources for sustained yields of wood, water, forage, wildlife, and recreation. Through forestry research, cooperation with the States and private forest owners, and management of the National Forests and National Grasslands, it strives—as directed by Congress—to provide increasingly greater service to a growing Nation.

The U.S. Department of Agriculture is an Equal Opportunity Employer. Applicants for all Department programs will be given equal consideration without regard to age, race, color, sex, religion, or national origin.

Pacific Northwest Research Station
319 S.W. Pine St.
P.O. Box 3890
Portland, Oregon 97208