

- 1.5 L150 (136,090kg. G.V.W.)
- THE L150 IS AN IDEALIZED FIVE AXLE OFF-HIGHWAY LOGGING TRUCK DESIGN VEHICLE.
 - THE L150 LANE LOAD CONSISTS OF A L150 TRUCK WITH EACH AXLE REDUCED TO 65% OF THE SPECIFIED VALUE SUPERIMPOSED WITHIN A UNIFORMLY DISTRIBUTED LOAD OF 37 kN/m AS SHOWN IN FIGURE 3.
 - APPLICATION
 - TRUCK AXLES THAT REDUCE THE LOAD EFFECT SHALL BE NEGLICTED.
 - THE UNIFORMLY DISTRIBUTED PORTION OF THE LANE LOAD SHALL NOT BE APPLIED TO THOSE PARTS OF A DESIGN LANE WHERE ITS APPLICATION DECREASES THE LOAD EFFECT.
 - FOR FLS AND SLS COMBINATION 1 AND 2, THE TRAFFIC LOAD SHALL BE ONE TRUCK ONLY, PLACED AT THE CENTRE OF THE TRAVELLED LANE. THE LANE LOAD SHALL NOT BE CONSIDERED. THE LATERAL WHEEL LOAD DISTRIBUTION SHALL BE 50%-50%.
 - FOR ULS, THE TRAFFIC LOAD SHALL BE THE TRUCK LOAD INCREASED BY THE DYNAMIC LOAD ALLOWANCE OR THE LANE LOAD, WHICHEVER PRODUCES THE MAXIMUM EFFECT. THIS LOAD SHALL BE PLACED LONGITUDINALLY AND TRANSVERSELY WITHIN THE DESIGN LANE AT A LOCATION AND IN A DIRECTION THAT PRODUCES THE MAXIMUM LOAD EFFECT BASED ON THE FOLLOWING:
 - FOR 4876 mm (16') WIDE DECKS, THE MAXIMUM TRANSVERSE ECCENTRICITY THAT SHOULD BE CONSIDERED FOR THE TRUCK AND LANE LOAD IS 400 mm FROM THE ROAD CENTRELINE
 - FOR DECK WIDTHS > 4876 mm (16') INCREASE THE TRANSVERSE ECCENTRICITY FROM THE ROAD CENTRELINE FOR THE TRUCK AND LANE LOAD BY 50% OF DECK WIDTH OVER 4876 mm.
 - THE LATERAL WHEEL LOAD DISTRIBUTION FOR THE TRUCK AND LANE LOAD SHALL BE 60%-40%.
 - FOR THE DESIGN OF DECKS AND OTHER COMPONENTS WHOSE DESIGN IS GOVERNED BY THE AXLE LOADS, THE TANDEM AXLE INCREASED BY THE APPLICABLE DYNAMIC LOAD ALLOWANCE SHALL BE CONSIDERED. THE LATERAL WHEEL LOAD DISTRIBUTION SHALL BE 60%-40%. FOR DECK OVERHANGS OR ADJACENT TO A CURB, RAILING, OR BARRIER, THE MINIMUM DISTANCE FROM THE CENTRES OF THE WHEELS TO THE CURB, RAILING, OR BARRIER WALL SHALL BE 0.40 M.

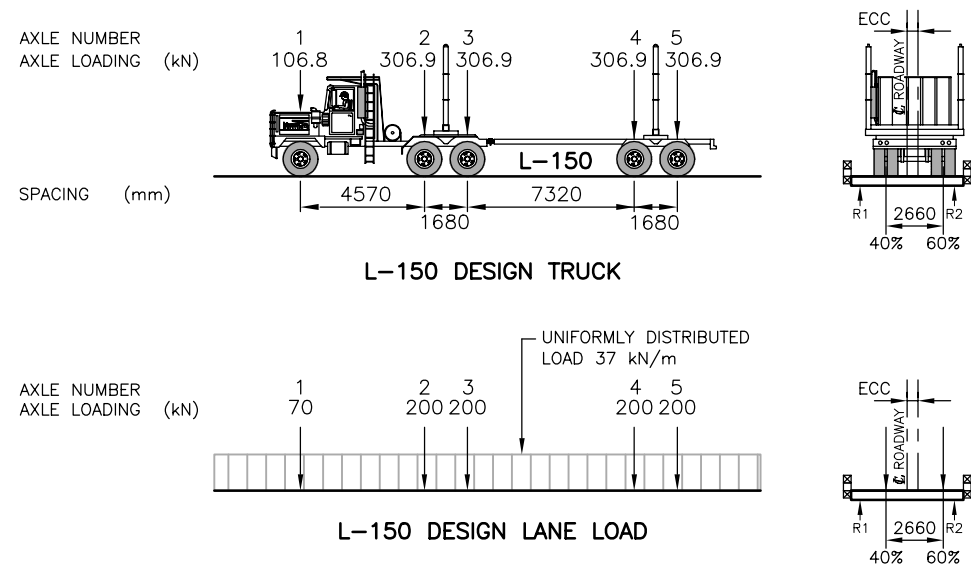

FIGURE 3
L-150 DESIGN VEHICLE LOADS

ASSUME NOT TO SCALE
ORIGINAL SIGNED AND SEALED

- 1.6 L165 (149,700kg. G.V.W.)
- THE L165 IS AN IDEALIZED FIVE AXLE OFF-HIGHWAY LOGGING TRUCK DESIGN VEHICLE.
 - THE L165 LANE LOAD CONSISTS OF A L165 TRUCK WITH EACH AXLE REDUCED TO 65% OF THE SPECIFIED VALUE SUPERIMPOSED WITHIN A UNIFORMLY DISTRIBUTED LOAD OF 41 kN/m AS SHOWN IN FIGURE 4.
 - APPLICATION
 - TRUCK AXLES THAT REDUCE THE LOAD EFFECT SHALL BE NEGLICTED.
 - THE UNIFORMLY DISTRIBUTED PORTION OF THE LANE LOAD SHALL NOT BE APPLIED TO THOSE PARTS OF A DESIGN LANE WHERE ITS APPLICATION DECREASES THE LOAD EFFECT.
 - FOR FLS AND SLS COMBINATION 1 AND 2, THE TRAFFIC LOAD SHALL BE ONE TRUCK ONLY, PLACED AT THE CENTRE OF THE TRAVELLED LANE. THE LANE LOAD SHALL NOT BE CONSIDERED. THE LATERAL WHEEL LOAD DISTRIBUTION SHALL BE 50%-50%.
 - FOR ULS, THE TRAFFIC LOAD SHALL BE THE TRUCK LOAD INCREASED BY THE DYNAMIC LOAD ALLOWANCE OR THE LANE LOAD, WHICHEVER PRODUCES THE MAXIMUM EFFECT. THIS LOAD SHALL BE PLACED LONGITUDINALLY AND TRANSVERSELY WITHIN THE DESIGN LANE AT A LOCATION AND IN A DIRECTION THAT PRODUCES THE MAXIMUM LOAD EFFECT BASED ON THE FOLLOWING:
 - FOR 4876 mm (16') WIDE DECKS, THE MAXIMUM TRANSVERSE ECCENTRICITY THAT SHOULD BE CONSIDERED FOR THE TRUCK AND LANE LOAD IS 450 mm FROM THE ROAD CENTRELINE
 - FOR DECK WIDTHS > 4876 mm (16') INCREASE THE TRANSVERSE ECCENTRICITY FROM THE ROAD CENTRELINE FOR THE TRUCK AND LANE LOAD BY 50% OF DECK WIDTH OVER 4876 mm.
 - THE LATERAL WHEEL LOAD DISTRIBUTION FOR THE TRUCK AND LANE LOAD SHALL BE 55%-45%.
 - FOR THE DESIGN OF DECKS AND OTHER COMPONENTS WHOSE DESIGN IS GOVERNED BY THE AXLE LOADS, THE TANDEM AXLE INCREASED BY THE APPLICABLE DYNAMIC LOAD ALLOWANCE SHALL BE CONSIDERED. THE LATERAL WHEEL LOAD DISTRIBUTION SHALL BE 55%-45%. FOR DECK OVERHANGS OR ADJACENT TO A CURB, RAILING, OR BARRIER, THE MINIMUM DISTANCE FROM THE CENTRES OF THE WHEELS TO THE CURB, RAILING, OR BARRIER WALL SHALL BE 0.40 M.

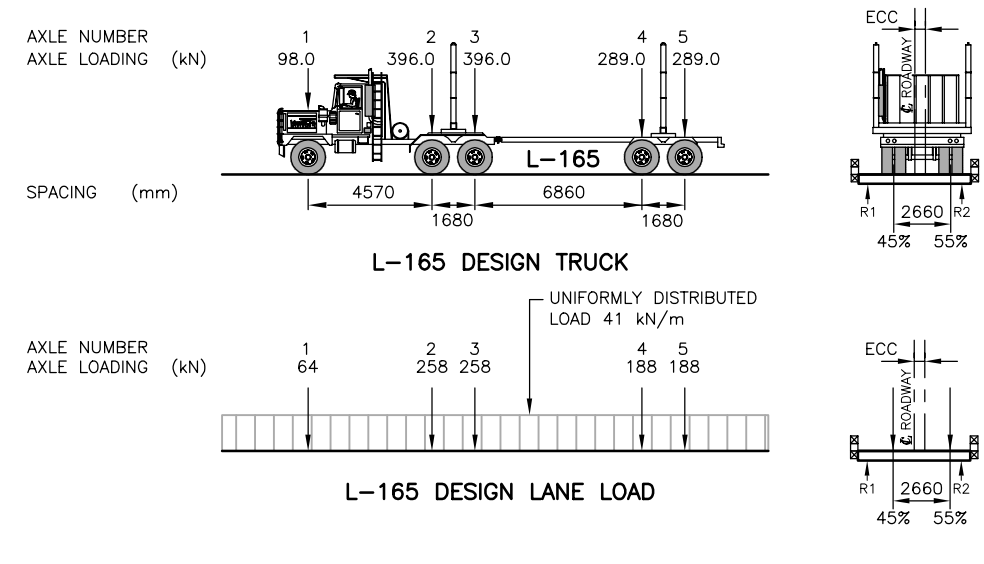

FIGURE 4
L-165 DESIGN VEHICLE LOADS

SCALE AS SHOWN		Designed J.H. Date MAR 2010	
		Checked D.J.H. Date MAR 2010	
		Drawn W.R. Date MAR 2010	
Rev	Date	DESCRIPTION	Init
REVISIONS			

BRITISH COLUMBIA
The Best Place on Earth

MINISTRY OF FORESTS & RANGE
ENGINEERING BRANCH, FIELD OPERATIONS DIVISION

STANDARD BRIDGE DRAWING

STANDARD BRIDGE DESIGN VEHICLES
SHEET 2

ORIGINAL SIGNED and SEALED BY:
JULIEN HENLEY

APPROVED BY:

DESIGN ENGINEER
JULIEN HENLEY

MOF ENGINEER

DATE

DATE

FILE No.

DRAWING No.
STD-EC-000-02