



Ministry of Forests



FOREST SERVICE BRIDGE DESIGN AND CONSTRUCTION MANUAL

**July 30, 1999
(Revised Drawings 2009)
(Appendix E Revised March 25, 2011)
Resource Tenures and Engineering
Branch**

Introduction

For bridges on Forest Service roads, the Ministry of Forests (MOF) is responsible for determining appropriate design and construction specifications.

In addition to the statutory requirements of the Forest Practices Code, technical and administrative practices and procedures must be applied to individual bridge projects. By standardizing such procedures, consistency is assured, and competition for supply, fabrication and erection of the structures is equitable. This manual provides the minimum expected administrative processes and specifications for the design, fabrication and construction of MOF bridges. All such details are required to ensure a suitable blend of strength and durability.

This manual provides detailed tendering procedures and design standards for the various bridge components and other design details, such as live load applications (including vehicle sizes) along with expected fabrication and inspection details. While MOF structures are industrial in nature, shortcuts in design and fabrication are often not acceptable. Industrial users normally are not set up to easily address major future maintenance problems. Rather, acceptance of some additional initial cost is usually preferable to a long-term risk of severe wear. Diligent, on-going surface maintenance should be the anticipated outcome, rather than major repairs.

This manual covers procedures for permanent structures on Forest Service roads. Should a temporary bridge, for example, be demonstrated as optimum at a particular location, there can be considerable variations from the design and contracting practices described here. For example, log stringer, used steel or portable superstructures may be considered for temporary crossings. For such structures, appropriate design and materials details can be found in documents such as Forest Engineering Research Institute of Canada (FERIC) *Log Bridge Handbook*, and Ministry of Forests standard drawings, usually available at regional offices.

TABLE OF CONTENTS

1. PROCEDURES AND DOCUMENTATION 1

<i>1.1 Bridge Classes.....</i>	<i>1</i>
<i>1.2 Stream Crossing Types.....</i>	<i>1</i>
1.2.1 Type 1 Crossing	1
1.2.2 Type 2 Crossing	1
1.2.3 Type 3 Crossing	1
1.2.4 Type 4 Crossing	1
<i>1.3 Preparation of Technical Documents.....</i>	<i>2</i>
1.3.1 General Requirements	2
1.3.2 Conceptual Bridge Design	2
1.3.3 Qualifications	3
1.3.4 Design and Erection Documents	3
<i>1.4 Tendering.....</i>	<i>4</i>
1.4.1 General Requirements	4
1.4.2 Bridge Class Tender Requirements	4

2. GENERIC DESIGN STANDARDS 5

<i>2.1 Mandatory Design Standards.....</i>	<i>5</i>
2.1.1 Guardrails	5
2.1.2 Deck	5
2.1.3 Steel Girders	6
2.1.4 Concrete Girders	6
2.1.5 Compo Girder™	7
2.1.6 Bearings	7
2.1.7 Abutments	7
2.1.8 Piers	8
2.1.9 Riprap	8
<i>2.2 Prohibited Design Details.....</i>	<i>10</i>
2.2.1 Composite Concrete Overlays	10
2.2.2 Pile to Girder Welding	11

3. DETAILED DESIGN STANDARDS 12

<i>3.1 Regulatory Framework.....</i>	<i>12</i>
<i>3.2 Design Responsibility.....</i>	<i>12</i>
<i>3.3 Design Objectives.....</i>	<i>12</i>
3.3.1 Safety	12
3.3.2 Cost Effectiveness	12
3.3.3 Environmental Concerns	12
3.3.4 Other Agency Approvals	13
<i>3.4 Live Loads.....</i>	<i>13</i>
3.4.1 Design Vehicle Loading	13

3.4.2 Design Truck	13
3.4.3 Dynamic Load Allowance	13
3.4.4 Number of Vehicles on the Bridge	13
3.4.5 Construction Loads	13
<i>3.5 Deflection</i>	<i>14</i>
<i>3.6 Durability</i>	<i>14</i>
<i>3.7 Structural Fatigue</i>	<i>14</i>
<i>3.8 Deck Geometry</i>	<i>14</i>
<i>3.9 Future Overlay</i>	<i>14</i>
<i>3.10 Alignment</i>	<i>14</i>
3.10.1 Approaches	14
3.10.2 Gradient	14
3.10.3 Turnout at Bridge End	14
3.10.4 Camber	15
3.10.5 Drainage	15
<i>3.11 Hydrology and Hydraulics</i>	<i>15</i>
3.11.1 Guidelines for Design Flood Estimation	16
3.11.2 Design High-Water Level	16

4. MATERIALS AND FABRICATION SPECIFICATIONS 16

<i>4.1 Material Identification</i>	<i>16</i>
<i>4.2 New or Innovative Materials</i>	<i>16</i>
<i>4.3 Bridge Identification</i>	<i>16</i>
<i>4.4 Structural Steel</i>	<i>17</i>
4.4.1 Material Standards	17
4.4.2 Welding Standards	17
<i>4.5 Steel Piles</i>	<i>17</i>
4.5.1 Material Standards	17
4.5.2 Welding Standards	17
4.5.3 Splicing of Piles	17
<i>4.6 Concrete</i>	<i>17</i>
4.6.1 Standards	17
4.6.2 Design Mix	18
4.6.3 Formwork	18
4.6.4 Grout	18
4.6.5 Lock Blocks	18
<i>4.7 Reinforcing Steel</i>	<i>19</i>
4.7.1 Standards	19
4.7.2 Epoxy Coating	19
<i>4.8 Timber</i>	<i>19</i>
4.8.1 Materials Standards	19
4.8.2 Pressure Treatment	19
4.8.3 Connectors	19

4.9 Other Materials 19

5. FABRICATION, INSPECTION AND REPORTING 20

5.1 Ministry Inspector’s Qualifications..... 20

5.2 Notice to Ministry Inspector 20

5.3 Steel Fabrication Quality Control..... 20

5.3.1 Ministry Inspection Scheduling 20

5.3.2 Welding Controls 20

5.3.3 Non Destructive Testing 21

5.3.4 Ministry Inspector’s Responsibilities 21

5.4 Precast Concrete Fabrication Quality Control.... 21

5.4.1 Ministry Inspection Scheduling 21

5.4.2 Storage and Curing 21

5.4.3 Ministry Inspector’s Responsibilities 22

6. TRANSPORTATION AND CONSTRUCTION 22

6.1 Transportation..... 22

6.2 Instream Work 22

6.3 Design Engineer’s Responsibility..... 22

6.3.1 Loading Specifications 22

6.3.2 Drawing Notes 22

6.4 Bridge Erector’s Responsibilities..... 22

6.5 Construction Tolerances 23

6.6 Construction Inspection and Professional Certification 23

6.6.1 Site Inspections 23

6.6.2 Site Inspector’s Qualifications 23

6.6.3 Certification of Construction 24

6.6.4 As-built Documentation 24

6.7 Site Cleanup 24

TABLES

Table 1 Riprap Size Classes and Allowable Velocities 13

Table 2 Guidelines for Selection of Methods for Estimating Design Peak Flows..... 22

Table 3 Requirements for Concrete Mixes 25

Figures

Figure 1 Plan - Bank and Pier Riprap..... 16

Figure 2 Section - Bank Riprap..... 16

Appendices

Appendix A Standard Drawings List

Appendix B	Vehicle Loading Diagrams
Appendix C	Sample Forms: Assurance of Field Reviews, Certification of Construction of Bridges and Major Culverts
Appendix D	Fabrication Inspection Report: Steel and Precast Concrete
Appendix E	Bridge and Major Culvert Site Plan Specifications
Appendix F	Manufacture of Prestressed Concrete Members
Appendix G	Bibliography

1. PROCEDURES AND DOCUMENTATION

This section outlines the administrative procedures to be used in the preparation of bridge documents, the tendering and awarding of contracts, the review of bridge designs and the monitoring of construction.

1.1 Bridge Classes

Class A bridges are defined as follows:

- construction cost not greater than \$250,000
- complete set of design drawings in tender documents.

Class B bridges are defined as follows:

- construction cost not greater than \$250,000
- partial set of design drawings in tender documents.

Class C bridges are defined as follows:

- construction cost greater than \$250,000.

1.2 Stream Crossing Types

1.2.1 Type 1 Crossing

- The stream has no significant potential for channel bank erosion.
- The stream design high-water width does not exceed 5 metres.

1.2.2 Type 2 Crossing

- The stream channel appears to be stable, as determined by air photo interpretation and field inspection.
- The channel banks are wooded or show no evidence of recent erosion or instability.
- There is no expectation of future destabilization of the upstream basin and stream channel due to logging or other forms of development.

1.2.3 Type 3 Crossing

- The stream channel appears to be stable and regular in cross-section, but air photographs or field inspection provide evidence of significant lateral shifting through the erosion of one bank and accretion of the other; or
- The crossing currently meets the Type 2 criteria, but there is reasonable expectation of possible future destabilization of the upstream basin and stream channel due to logging or other forms of development.

1.2.4 Type 4 Crossing

- The stream channel is unstable in cross-section and plan.
- There is strong evidence of active lateral shifting.
- The overall floodway channel contains shifting bars, islands, and low-water subchannels. Braided channels and alluvial fan streams represent extreme cases of this type of crossing.
- The stream design high-water width exceeds 5 metres.

1.3 Preparation of Technical Documents

1.3.1 General Requirements

The documents described below must be prepared for all bridges and must incorporate the generic design standards described in this manual (see 2.0 Generic Design Standards).

1.3.2 Conceptual Bridge Design

The Conceptual Bridge Design Report shall include the following information:

- Site Plan
- Site Report
- Conceptual Bridge Design drawings.

Site Plan

The site plan must conform to the requirements of Appendix E, “Bridge and Major Culvert Site Plan Specifications” and shall be prepared by capable survey staff working under the technical direction of a qualified professional engineer.

Site Report

The site report shall include the site specific hydrologic, hydraulic, geotechnical reports where required, which include the following information as a minimum:

- rationale for proposed conceptual design, noting any particular circumstances or significant design criteria such as debris or installation considerations;
- design water level, flow rate and velocities and methodology used for development of design flood hydrology and who developed the design flood flow rate;
- the design ice pressure and corresponding thickness, the maximum scour depth, the riprap design and minimum stream channel widths, whenever such items are applicable;
- the geotechnical report must include recommendations on the following design issues where applicable:
 - foundation type
 - pile type and capacity
 - allowable bearing capacities
 - bank stability for location of substructure
 - methods and extent of geotechnical assessment
 - rationale for any recommendations and assumptions.

The site report shall also specify the following:

- bridge class
- stream crossing type
- zones in which abutment and pier substructure can be placed
- bridge alignment
- vertical clearance above design water level
- environmental restrictions
- site-specific design or construction restrictions.

Conceptual Bridge Drawings

The **Conceptual Bridge Design drawings** shall at a minimum include a plan view and elevation view of the new bridge. These conceptual drawings shall be overlain on the site plan and cross sections, and shall include the following information:

- design vehicle for loading (and side tracking if applicable);
- length, width and grade of the bridge deck;

- location of the superstructure and substructure components relative to the stream and road approaches,;stream flow direction, design water elevation and design flow rate;
- proposed configuration/arrangement and estimated depth of superstructure and reference to any MOF standard drawings if applicable for Class A bridges, or site-specific geometry, erection, environmental or other limitations/constraints that a designer must work within in preparing the final design;
- proposed realignment of the existing road approaches or stream if applicable;
- proposed approach road grades;
- location and elevation of all other critical geometric points such as wingwall length and fill spill lines for Class A bridges, or site-specific geometric, erection, environmental or other limitations/constraints that a designer must work within in preparing the final design;
- proposed arrangement of riprap placement for Class A bridges, or site-specific geometric, erection, environmental or other limitations/constraints that a designer must work within in preparing the final design;
- proposed sources of riprap, where available;
- proposed details of approach fenders, if applicable;
- notes detailing any unusual construction requirements such as a temporary bridge, ford or detour, etc.

1.3.3 Qualifications

The geotechnical, hydrologic and hydraulic studies must be performed by specialists for all Class C bridges and, where considered necessary by the ministry, for individual Class A and Class B bridges.

The hydrologic and hydraulic studies must be performed by specialists for all Type 4 crossings and, where considered necessary by the ministry, for individual Type 2 and Type 3 crossings.

Studies for other bridge classes or crossing types must be carried out by a professional engineer, although not necessarily a specialist.

1.3.4 Design and Erection Documents

Design Drawings

For Class B bridges, the contractor must prepare design drawings that constitute a full and comprehensive set together with the tender design drawings. These design drawings must conform to the generic or approved design standards in this manual (see Part 2, “Generic Design Standards”).

For Class C bridges, the contractor must prepare a full and comprehensive set of design drawings that conform to the generic or approved design standards in this manual.

The contractor's 100 percent complete design drawings must be submitted, with each drawing signed and sealed by the designer, as required by the ministry.

Project design drawings shall be developed for each structure. The design drawings and specifications shall show:

- general arrangement
- foundations and foundation protection works
- design high-water level and present water level
- other site-specific requirements
- design loads
- reference design codes and standards
- selected design criteria
- material and fabrication specifications and standards
- requirements of manufacturer's qualifications
- requirements of transportation and construction
- quality assurance requirements
- signature and seal of the design engineer (conditional wording will not be accepted).

Review Drawings

For Class B and Class C bridges, the contractor must submit an intermediate set of design drawings to the ministry. This intermediate set of design drawings must illustrate bridge layout, type of superstructure, type of substructure and all primary geometry.

The contractor must submit a set of design drawings to the ministry for review at the 100 percent design completion stage.

Erection Drawings

If specified by the ministry, the contractor must submit a set of erection drawings to the ministry for review at the 100 percent design completion stage.

Design Notes

If specified by the ministry, the contractor must submit: a full set of design notes to accompany the set of 100 percent complete design drawings, and a full set of erection design notes to accompany the set of 100 percent complete erection drawings (where such drawings have been specified by the ministry). This will be rare.

1.4 Tendering

1.4.1 General Requirements

Bids will only be accepted if the contractor's proposed design conforms with the ministry's tender documents.

In the award of a contract:

- The ministry reserves the right to reject any or all bids.
- The contract will normally be awarded to the lowest bidder who conforms with the ministry's tender documents.
- No payments will be made to the unsuccessful bidders for preparing their bids.

1.4.2 Bridge Class Tender Requirements

Class A Bridges

Tenders for Class A bridges shall include the following requirements:

- Bids must conform to all mandatory design standards (Section 2.1).
- Bidders may substitute a different type of **ministry-approved** component with similar overall dimensions to those shown on the design drawings. (eg., substituting between prestressed slabs, reinforced slabs, prestressed boxes and Compo-Girder™ Inverted Channel girder or between steel I-girders, prestressed I-girders and Compo-Girder™ I-girders, or between conventional and ArchPanel concrete deck slabs).
- Bids must not incorporate any prohibited design or construction practices.

Class B Bridges

Tenders for Class B bridges shall include the following requirements:

- Bids must conform to all mandatory design standards (Section 2.1).
- Bids must not incorporate any prohibited design or construction practices.

Class C Bridges

Tenders for Class C bridges shall include the following requirements:

- Bids must not incorporate any prohibited design or construction practices.
- If bids incorporate alternatives to the ministry's mandatory design standards, contractors must make their submissions to the ministry for consideration no later than the first week of bidding.

- Contractors can use approved alternatives to mandatory design standards only if the ministry issues its approval before the end of the second week of bidding.
- All ministry-approved alternatives to the mandatory design standards will be circulated to all bidders.

2. GENERIC DESIGN STANDARDS

The generic design standards for permanent bridges are an integral part of the design/build process.

The objectives of generic design standards are to:

- provide minimum performance standards, in the form of mandatory design standards and prohibited design and construction practices;
- emphasize details that result in the lowest life-cycle cost (construction cost plus present cost of maintenance over the lifetime of the bridge);
- present contractors with a choice of acceptable details and a list of prohibited practices;
- achieve design efficiency and quality by producing standard drawings for components that exhibit limited variation.

The ministry welcomes input from design professionals and others in the construction industry to assist it in refining and improving these standards.

Refer to Sections 1.1 and 1.2 for definitions of bridge classes and stream-crossing types.

2.1 Mandatory Design Standards

All designs must conform to the mandatory design standards detailed in this section.

2.1.1 Guardrails

Guardrail design must conform to one of the design options given in the ministry's standard drawing STD-E-010-01 in Appendix A.

2.1.2 Deck

The bridge deck must consist of one of the following forms of construction:

- timber cross ties, timber decking and running planks
- precast concrete panels
- cast-in-place concrete
- top flange of concrete box girders or slab girders.

Timber Deck

Timber deck design must conform to the details given in the ministry's standard drawing series STD-E-02 in Appendix A.

Stress laminated timber decks are an acceptable alternative timber deck and their design must conform to the latest edition of the Ontario Highway Bridge Design Code.

Precast Concrete Panels

Precast concrete deck panels can be of composite or non-composite construction.

Standard stud or angle shear connectors must be used to connect the composite deck panels to the girders. Non-composite deck panels must be connected to the girders with either studs or by bolts and couplers.

Skews may be accommodated by either skewing all the deck panels or just the end deck panel at the designer's preference.

Composite precast concrete deck panels must conform to the ministry's standard drawing series STD-E-03 in Appendix A. Alternatively, the proprietary ArchPanel (Steel Free Deck Panel) may be specified and must conform to the ministry's standard drawing STD-E-011-10 in Appendix A. Non-composite precast concrete deck panels must conform to the ministry's standard drawings when such drawings become available for distribution.

The transverse joints between composite panels must be composed of a grouted joint.

The transverse joints between non-composite panels must be sealed at the top of the joint.

Lifting devices for precast concrete deck panels must conform to those specified in the ministry's standard drawings or approved alternatives.

2.1.3 Steel Girders

Field welding of steel girders is not permitted except as pre-approved by the ministry. All welded or bolted connections must be sealed against moisture. All exposed steel surfaces must be accessible, easily inspected and easily maintained.

2.1.4 Concrete Girders

Concrete girders must be composed of one of the following:

- prestressed box girders
- prestressed I-girders
- prestressed slab girders
- non-prestressed slab girders (voided or solid)
- Compo-Girder™.

Box Girders

Prestressed concrete box girders must conform to the details given in the ministry's standard drawing series STD-E-06 in Appendix A. If a custom design is required to accommodate non-standard bridge widths, greater than 20 degree skews, or different spans than shown on the tables etc, the following variations to the ministry's standard are allowed:

- The girder depth may vary.
- The section wall thickness may be increased only.
- The reinforcing and prestress strand layout may vary so long as the design criteria shown on the standard drawing STD-E-06-01 is followed.

Reinforced Concrete Slab Girders

Non-prestressed slab girders must conform to the details given in the ministry's standard drawing series STD-E-07 in Appendix A. If a custom design is required to fine tune piece weight, to accommodate non-standard bridge widths, greater than 20 degree skews, or different spans than shown on the tables etc., minor variations in girder geometry and reinforcing layout are acceptable with approval by the ministry.

The design criteria shown on drawing STD-E-07-01 shall be followed.

All slab girders with aspect ratios (span/width) of greater than 2 shall be designed as flexural members rather than slabs with respect to shear.

Prestressed Slab Girders

Prestressed slab girders must generally conform to the details given in the ministry's standard drawing series STD-E-08 in Appendix A. If a custom design is required to accommodate non-standard bridge widths, greater than 20 degree skews, or different spans than shown on the tables etc., the following variations to the ministry's standard are allowed:

- The girder depth and void size may vary.
- The reinforcing and prestress strand layout may vary so long as the design criteria shown on the standard drawing STD-E-06-01 is followed.

Welded Shear Keys

Until the ministry completes its study and evaluation of welded shear key connections for slab girders, the following design procedures shall be followed. Welded shear keys may be used to connect reinforced concrete slab girders and inverted channel compo girders only if:

- the girders are designed for the Ultimate Limit State assuming all shear connections have failed and each girder is acting independently;
- the girders are designed for the Service Limit State (crack control, fatigue and deflection) assuming all shear connections are intact;
- approval from the ministry is received for each specific project.

2.1.5 Compo Girder™

The proprietary Compo-Girder™ I-beam and inverted channel girder are acceptable by the ministry and must conform to the typical details and configurations shown in the ministry's standard drawings STD-E-011-01 and STD-E-011-02.

2.1.6 Bearings

General Requirements

Bearings are to be provided for all types of girders.

Permissible bearing types are:

- elastomeric (reinforced or unreinforced)
- confined elastomeric (pot).

Bearings must be protected against water ponding or accumulation of debris.

Elastomers must meet the minimum physical properties given in Section 11.5 of CAN/CSA-S6-88, "Design of Highway Bridges."

Design Requirements

Bearings must be designed in accordance with Section 11.5 of CAN/CSA-S6-88, "Canadian Highway Bridge Design Code."

Bearings must be designed for the factored translation and/or rotation of the superstructure.

Steel reinforced elastomeric bearings shall have a minimum of two steel reinforcing plates and the cover of elastomer for the top and bottom plates shall be 5 mm. Side cover on all reinforcing plates shall be 5 mm.

2.1.7 Abutments

Abutments must have one of the five following foundation types:

- piled
- pad and post
- spread footing
- bin walls
- concrete lock-blocks.

Piled Foundations

Piled abutment foundations can be used for all stream crossings. In soils where there is potential for scour, pile tips must penetrate at least 4.5 m below maximum scour depth.

The design engineer must specify the required pile capacity and minimum penetration for driven piles.

Post Foundations

Post abutment foundations can be used if all of the following conditions are met:

- The stream crossing is a Type 1 or Type 2 (refer to Section 1.2); or it is a Type 3 and the riprap protection is enhanced (refer to Section 2.1.9); or it is a Type 4 crossing and hydrologic and hydraulic studies (specified in Section 1.3.3) permit post abutment foundations, and the foundations are approved by the ministry.
- All posts are supported on spread footing pads.
- Tie-backs are provided where the height of fill retained by the exposed posts exceeds 1.5 metres.
- All buried steel is protected against corrosion using a protection system approved by the ministry such as Zymax Monoguard™ or a similar pre-approved Coal Tar Epoxy.

See drawing STD-E-05-10 in Appendix A for a typical pad and post design for a 2 girder steel bridge.

Spread Footing

Spread footing abutment foundations can be used on a Type 1 stream crossing or on stream crossings where the foundations are set on rock or a non-erodible material and the non-erodibility of the material is confirmed by a geotechnical report.

See drawing STD-E-05-11 in Appendix A for a typical spread footing design for a 2 girder steel bridge.

Bin Wall

Bin wall abutment foundations can be used under either of the following conditions:

- The stream crossing is a Type 1 or Type 2.
- The stream crossing is a Type 3 and hydrologic and hydraulic studies (specified in Section 1.3.3) permit bin wall abutment foundations, and the foundations are approved by the ministry.

Concrete Lock Block

Concrete lock block abutment foundations can be used under the following conditions:

- The span length does not exceed 20 metres.
- For all stream crossing types except Type 1, hydrologic and hydraulic studies (specified in Section 1.3.3) confirm that lock block abutment foundations are acceptable and the foundations are approved by the ministry.

See drawings STD-E-05-30 - 32 in Appendix A for lock block abutment concepts.

Pile Caps

- Pile caps must be used for all multiple or single-span bridges where the span length exceeds 30 metres.
- Steel pile caps must be fully accessible for inspection and maintenance.
- Concrete pile caps must be used for all Class C bridges.
- Concrete pile caps must be used to support concrete girders listed in Section 2.1.4.

See drawings STD-E-05-20, 22 in Appendix A for concrete and steel cap beam concepts.

Pile Cap Connections

- For Class C bridges, piles must be connected to precast concrete caps with full penetration welds, unless approved by the ministry.

Abutment Ballast Walls

- Ballast walls must be of concrete construction or of an alternative construction pre-approved by the ministry.
- Welded connections for ballast walls must not be buried in soil.
- All welded connections must be protected with two coats of zinc-rich primer.

See drawings STD-E-05-01,02 for a typical ballast wall design for a 2 girder steel bridge.

2.1.8 Piers

Pier Foundations

For crossings where the ice strength does not exceed 700 kiloPascals (kPa), pier foundations may be composed of a single row of pipe piles, with diaphragms between adjacent piles. Where the ice strength exceeds 700 kPa, the type of pier foundation proposed by the contractor must be specified in the contractor's bid and is subject to the approval of the ministry.

- Pipe piles located within the wetted perimeter must be filled with either concrete, sand or gravel.

See drawing STD-E-05-21 in Appendix A for concrete and steel cap beam concepts.

Pier Pile Caps and Connections

- Pile caps must be connected to the superstructure and substructure for the transmission of all transverse and longitudinal forces.
- For Class C bridges, piles must be connected to precast concrete caps with full penetration welds, unless approved by the ministry.

2.1.9 Riprap

Applicability

The following riprap guidelines are restricted to Class A and Class B bridges that span either Type 2 or Type 3 stream crossings (defined in Part 1, "Design/Build Process"). In the case of Type 1 crossings, riprap may be eliminated where approved by the ministry. In the case of Type 4 crossings, special design of channel training works and riprap protection is required, as specified in Section 1.3.3.

Use

Riprap must be used to prevent or retard erosion and scour in the vicinity of bridge piers and abutments. Bank erosion near abutments may result from natural shifting of the stream channel, or from disturbances to natural banks caused by bridge and road construction. Bed scour near piers and abutments may result from severe floods, degradation of the stream profile over time, local eddy currents around piers and projecting abutments, or lateral shifting of the thalweg (deepest part of channel). Riprap generally requires periodic inspection and maintenance, especially after major floods.

Sources

Riprap must be made up of sound, durable quarry or talus rock that will not deteriorate during freeze-thaw cycles or on exposure to water or the atmosphere. Durability testing and approval of rock sources may be required. Where quarry rock is not reasonably obtainable, non-rounded boulder sources may be approved. Average solid density must not be less than 2.4 tonnes per cubic metre.

Nominal Size

Riprap particles must be of a nominal size of at least 200 mm (as measured along the rock's intermediate axis), and in a mixture in which no more than 50 percent by mass is finer than the median (D_{50}) size. In case of dispute, size will be calculated according to the equivalents shown in Table 1.

Size Selection

The nominal size for a specific application should be selected according to the expected local flow velocity under design flood conditions, according to Table 1. Local velocity means the vertically averaged value at a specific point on the channel cross-section. In case of doubt as to the appropriate velocity, the next larger nominal size should be used.

Where post abutments are approved for Type 3 stream crossings, a rock size larger than otherwise indicated shall be used.

Velocities may be estimated from actual flood observations and adjusted to design flood conditions, or from calculation of flood depths and velocities using the gradient, cross-section and estimated roughness of the stream channel. In estimating local velocities, cross-sectional shape and plan curvature must be taken into account.

Alternatively, from extensive experience, riprap sizes may be based on the performance of equivalent installations on the same stream or in hydraulically similar situations. In streams with coarse alluvial beds, a rough guide is to ensure the nominal size of bank riprap is at least twice the size of the largest stones on the stream bed.

Table 1 Riprap Size Classes and Allowable Velocities

Nominal (D_{50}) size (mm)	Equivalent mass (kg)	Maximum allowable velocity (m/s)
200	10	2.5
300	35	3.0
450	125	3.6
600	280	4.2
800	700	4.8
1000	1300	5.3
1300	2800	6.0

Thickness and Underlayer

The thickness of a riprap layer must not be less than 1.75 times the nominal rock size or not less than the long axis of the largest rocks in the mixture, whichever is the greater. Where riprap is placed on top of soil such as fine gravel, sand or silt, a layer of coarse gravel or equivalent quarry rock not less than 100 mm thick must be placed between the soil and the riprap.

Rock Shape

On average, the ratio of long axis to short axis in a rock should not exceed 2, and no rock should have a ratio exceeding 3.

Grading

Where practicable, the ratios of D_{100} size to nominal size, and of nominal to D_{20} size, should not exceed 1.5. Where such a narrowly graded mixture is not reasonably obtainable, more widely graded or quarry-run material of equivalent nominal size may be approved if a greater thickness is provided. Gap-graded material liable to excessive segregation is not acceptable.

Bank Slope

Riprap on stream banks should normally be placed on a slope of 1 vertical to 2 horizontal. Steeper slopes may be approved where there would otherwise be excessive encroachment into the channel or difficulty in matching natural slopes, but in no case should the slope be steeper than 1 to 1.5.

Where a slope steeper than 1 to 2 is used, a larger rock size must be used.

Placement

Riprap must be laid out to ensure an even distribution of rock sizes over the area covered. The placed material shall be tamped or otherwise treated to provide an even, dense surface with a minimum of voids.

Use of hand-placed rock or grouted riprap of smaller size and thickness may be approved by the ministry in special cases.

Length of Bank Riprap

Where the bridge is located in a reasonably straight reach and the abutments are at or near the stream banks, bank riprap should normally be provided on both banks on either side of bridge centreline (Figure 1). The length along each bank must not be less than the width of the disturbed zone resulting from road and bridge construction, or less than 20 percent of the channel width, whichever is the greater.

Where the bridge is located in a channel bend and there is evidence that one bank is subject to erosion and the other to accretion, riprap may be restricted to the eroding bank only. In bends where both banks may be subject to erosion, smaller riprap may be placed on the inner bank.

The ends of bank riprap must be keyed at least 1 metre into the bank in trenches, as indicated in Figure 1.

Cross-section of Riprap

The upper limit of riprap must be the top of the bank or the design flood level, whichever is lower. A horizontal apron or a thickened toe must be provided, containing a sufficient volume of rock to cover potential scour development (see Figure 2). Scour level must be taken as no higher than the deepest point in the channel in the general vicinity of the bridge, or as 1.5 metre below local bed level, whichever is lower.

Pier Riprap

Riprap may be required around the foundations of in-channel piers. Pier riprap must consist of a horizontal apron flush with the stream bed, extending all around the pier or footing for a distance equal to at least 1.5 times the pier width. See Figure 1.

2.2 Prohibited Design Details

2.2.1 Composite Concrete Overlays

Composite concrete overlays are not permitted on concrete girders.

2.2.2 Pile to Girder Welding

Direct welding of steel piles to steel girders is not permitted. A pile cap or bearings must be provided at the pile/girder interface.

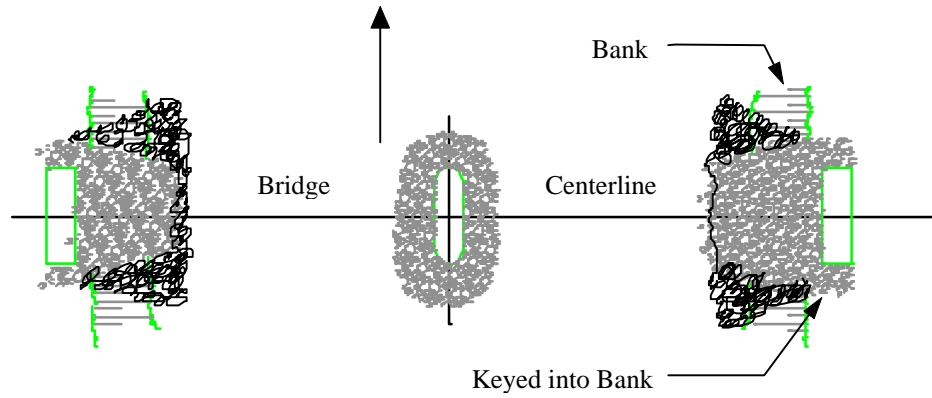

Figure 1: Plan - Bank and Pier Riprap

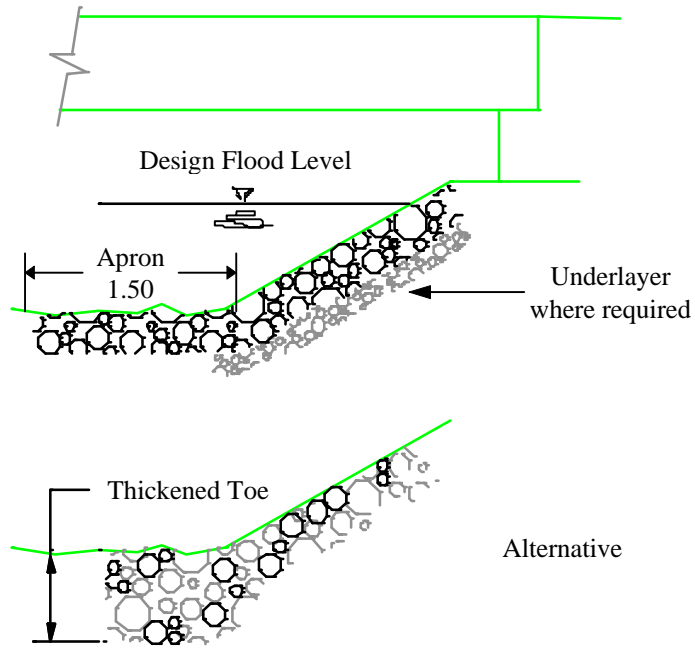

Figure 2: Section - Bank Riprap

3. DETAILED DESIGN STANDARDS

3.1 *Regulatory Framework*

The Forest Road Regulation requires that permanent bridges be designed by a professional engineer registered in British Columbia.

Part 2 of the regulation further requires that bridges be designed in accordance with the requirements of CAN/CSA-S6-88 “Design of Highway Bridges” and with the requirements of the *Canadian Foundation Engineering Manual*.

The standards presented here list the basic design requirements for Forest Service permanent bridges.

3.2 *Design Responsibility*

Bridges must be designed by a professional engineer registered with the Association of Professional Engineers and Geoscientists of British Columbia.

Every project shall have an Engineer of Record who takes responsibility for the project from conceptual design through to completion of construction. The Engineer of Record shall be responsible to ensure the completed structure in its entirety meets the objectives and requirements detailed in the conceptual design drawings and reports, given that he or she may be required to rely upon the results of reports prepared by others for guidance in geotechnical, hydrology and hydraulics applications.

The preferred scenario is for the Engineer of Record to be the conceptual design engineer since he/she is involved from the project start and is most familiar with the site-specific concerns and constraints. However, the Engineer of Record may also be the engineer responsible for detail design or another engineer with a vested interest in the engineering portion of the project. If the Engineer of Record is not also the detailed design engineer, the Engineer of Record is responsible to review the detailed design and provide written documentation to the ministry confirming the detailed design meets the objectives and requirements of the conceptual design and site reports. The conceptual design engineer shall be responsible for preparing the site plan and site reports, and selecting the bridge concept which meets all the objectives and requirements of the site plan and site reports. In the case where the site plan is prepared by others, the conceptual design engineer shall take reasonable steps to verify that the information on the site plan is accurate. The detailed design engineer shall sign and seal all design drawings prepared for the project, and must be responsible for approving any changes made during construction. Both elements of project work must be reflected in their service contract.

3.3 *Design Objectives*

3.3.1 *Safety*

In the interpretation and application of the Bridge Design Code and the standards presented here, the primary concern must be safety of the public, including that of construction and maintenance workers.

3.3.2 *Cost Effectiveness*

Provided that all safety provisions are met, cost effectiveness of the structure must be considered in selecting the structure type and materials.

3.3.3 *Environmental Concerns*

Bridges and their associated works must be designed to comply with all established environmental requirements. The design must include assessment of possible environmental effects due to bridge construction and must limit any adverse effects to a practical minimum.

3.3.4 Other Agency Approvals

Where appropriate, approvals for bridge construction must be sought from other agencies. Bridge construction over navigable waters must be approved by Transport Canada, according to the *Navigable Waters Protection Act*. An approval may have to be obtained from the Ministry of Environment, Lands and Parks for crossing streams where fish are present.

3.4 Live Loads

All bridges shall be single-lane bridges, unless otherwise specified. Bridges must be designed according to the Highway Bridge Design Code CAN/CSA-S6-88, with the following variations. When the new Canadian Highway Bridge Design Code comes into effect, it shall supersede CAN/CSA-S6-88.

3.4.1 Design Vehicle Loading

The design vehicle loads must be logging truck wheel loads, with eccentricities and unbalanced axle loads as noted in "Vehicle Loading Diagrams" in Appendix B. Note, the eccentricities shown in Appendix B only apply to 2 girder bridges with girders either 3.0 or 3.6 m apart, otherwise use CAN/CSA-S6-88 curb offsets.

3.4.2 Design Truck

The minimum design vehicle load for all new and replacement bridges must generally be based on an L-75 logging truck. For any design load used, the load diagram must be selected from Appendix B, and the bridge designed accordingly.

3.4.3 Dynamic Load Allowance

The dynamic load allowance shall be 0.30 for all bridges and all bridge components.

3.4.4 Number of Vehicles on the Bridge

Bridges with a total length between abutments not exceeding 40 metres must be designed for loads imposed by one design vehicle. Bridges with a total length over 40 metres must be designed for two-vehicle loads with a distance between them equal to half the vehicle length.

3.4.5 Construction Loads

The design engineer must consider the weight of materials, work crews and equipment supported during construction.

Except for bridges constructed by incremental launching, maximum permissible construction equipment loads must be specified by the design engineer. The engineer's drawings must require that the actual equipment loads be obtained by the contractor from the manufacturers of equipment and confirmed with the engineer.

Where a bridge will be installed under a separate contract from the design/supply contract for the main bridge components, the ministry shall provide all design/supply bidders a set of erection loads (or anticipated erection procedures) to be considered in the design. This will ensure fairness in the bidding process and will ensure the supplied bridge components can be erected in a safe manner.

The following is an example erection loading for a composite steel girder bridge with precast concrete deck panels that will be erected by a 40 ton excavator working from the bridge.

- self weight of the structure, supported at the bearings, including all deck panels in position but ungrouted
- a vertical live load of 445 kN (40 ton equipment + 10 ton panel) distributed over a length of 4 m, positioned on the bridge to produce the maximum effect, considered as an exceptional load case at Ultimate Limit State
- a uniformly distributed wind load of xx kPa applied horizontally, perpendicular to the longitudinal axis of the structure.

3.5 Deflection

Bridges must be designed so that live load deflection (calculated as that caused by one truck only, placed at the centre line of the travelled roadway, dynamic load allowance included) does not exceed Span/350 for concrete slab girder and Inverted Channel Compo-Girder™ bridges and Span/450 for all other bridges.

3.6 Durability

Unless approved otherwise, the design life of all new structures shall be a minimum of 45 years. Material selection and specified quality control shall ensure that the design life of all major structural components is achieved. It is acceptable that other non structural components that are prone to deterioration may need periodic replacement during the design life of the structure.

3.7 Structural Fatigue

Components, connections and welds subjected to repeated tensile stress or stress reversal shall be designed for a fatigue limit state of 500,000 stress cycles, including dynamic load allowance. Steel plate girders shall be designed and fabricated as fracture-critical. The vehicle used to calculate fatigue shall have zero lateral eccentricity and a 50/50 wheel split.

On a project by project basis, and only with approval from the ministry, bridges designed for the L-165 logging truck may be designed for fatigue using a lighter logging truck that better represents the most common logging truck using the bridge. If this is done, the distinction shall be clearly noted on the bridge drawings and as-built records.

3.8 Deck Geometry

Roadway widths and curb widths and heights must comply with the ministry standard bridge deck geometry, as noted on the ministry's standard drawings in Appendix A. The standard roadway width on bridges is 4.3 metres for L75 and L100 trucks and 4.9 metres for L150 and L165 trucks. Decks shall be widened to accommodate vehicle sidetracking on road curves and to accommodate site-specific safety concerns. The design vehicle used for sidetracking will be specified by the ministry on a project basis.

3.9 Future Overlay

Bridges with concrete as the running surface must be designed for a future 50 mm concrete overlay.

3.10 Alignment

Bridge alignment and plan geometry must be designed to suit site conditions, to accommodate present and future logging traffic and to meet road user safety and sight stopping distance criteria.

3.10.1 Approaches

Where possible and at reasonable cost, the approach road alignment shall be vertically and horizontally tangent to the bridge deck for at least 10 metres at either end of the bridge. At all locations the approaches shall provide a smooth transition on to the bridge.

3.10.2 Gradient

The longitudinal gradient on bridge decks shall not exceed 4 % in the interior or in snow and ice conditions, unless written approval from the ministry is received.

3.10.3 Turnout at Bridge End

Where required by the ministry, a vehicle turnout shall be provided at one end of a single lane bridge (within both approach site lines) to accommodate passing vehicles. Turnouts may be needed at both ends of the bridge for longer span bridges or for other safety reasons.

3.10.4 Camber

Bridge spans in excess of 20 metres shall be cambered for 115 percent of the design dead load deflection. For spans 20 metres or less, the degree of camber is left to the designer's judgement and preference.

3.10.5 Drainage

Drainage on all bridge decks except timber decks, precast slabs, inverted channels and box girder bridge decks, shall be achieved by providing a minimum 2% transverse cross-fall. Where geometry permits, a minimum longitudinal grade of 0.5% shall also be provided.

Bridge approaches shall have adequate drainage controls to minimize sediment deposition onto bridge decks and into streams.

3.11 *Hydrology and Hydraulics*

All bridges shall be designed to accommodate the design flood (100-year return period for permanent bridges) including any floating debris where applicable without resulting damage to the structure, approaches and abutments, downstream resources or environmental values. All bridges subject to potential debris torrents and debris flows shall be designed to accommodate the debris torrents and debris flows without the above damage unless otherwise directed by the ministry.

3.11.1 Guidelines for Design Flood Estimation

The design flood discharge should be estimated according to recommended methods shown below in Table 2.

Table 2 Guidelines for selection of methods for estimating design peak flows

(Source: *Manual of Operational Hydrology in British Columbia*, B.C. Ministry of Environment, 1988)

Drainage area (km ²)	Availability of hydrometric data				
	None	Less than 5 years		More than 5 years	
		On site	Nearby watershed	On site	Nearby watershed
<10	rational formula	unit hydrograph or model	unit hydrograph transfer or model	frequency analysis	frequency analysis
10 - 100	regional	unit hydrograph or regional	regional	frequency analysis	frequency analysis and regional
>100	regional	regional	regional	frequency analysis and regional	frequency analysis and regional

3.11.2 Design High-Water Level

The design high water level should be the higher of:

- the water level corresponding to the design flood discharge under ice-free conditions, with an allowance for floating debris;
- the water level caused by ice jams and having a return period comparable to that of the design flood (where applicable).

4. MATERIALS AND FABRICATION SPECIFICATIONS

4.1 Material Identification

All materials used for the construction of permanent bridges must be new. The materials or material combinations must conform to applicable CSA or ASTM standards and must have the appropriate supporting identification.

4.2 New or Innovative Materials

Newly developed or innovative materials or material combinations must be pre-approved by the Ministry of Forests, and may be considered only after they have been tested and evaluated for strength and durability. To be acceptable as a substitute for standard materials, these materials or material combinations must be of the same or better strength and durability than the standard materials used for that application.

4.3 Bridge Identification

Each bridge must have the following information clearly stamped or permanently marked on the exterior side of one girder:

- identification
- load rating
- manufacturer’s name
- date of manufacture
- the words “Ministry of Forests.”

The height of lettering must be at least 50 mm.

4.4 Structural Steel

4.4.1 Material Standards

Structural steel for permanent applications must comply to CSA Standard CAN3-G40.21-M, Structural Quality Steels or to a pre-approved equivalent specification. Primary tension members of welded structures must be of type AT, grade 350 or better. The appropriate low temperature impact category must be specified for all AT type steels. All other steel must comply to grade 350, type A.

- Weathering steel shall not be used in marine coastal areas or in areas where there is potential for road de-icing salts to come in contact with the bridge, either directly or by being tracked on from nearby roads. Alternatively, galvanized or painted structural steel must be specified in these areas.
- All bolts for structural steel work must be ASTM A-325M.
- Steel plates for main members, splice plates for flanges and main tension members shall be cut and fabricated so the direction of rolling is parallel to the direction of the primary stresses.

4.4.2 Welding Standards

All shop and field welding must be in accordance with CSA Standard W59. Fabricators responsible for welded construction must be certified for division 1 or division 2.1 of CSA Standard W47.1, Certification of Companies for Fusion Welding of Steel Structures. All flange to web welds on bridge girders shall be made by an automatic process which provides a continuous weld throughout the length of the member. All welding shall be done under suitable cover. The Ministry of Forests may apply additional conditions to ensure that fabricators are qualified for bridge girder welding.

Weld quality shall be inspected and interpreted in accordance with Clause 12 of CSA Standard W59. One hundred percent of all welds shall be visually inspected and 100% of the tension portion of all butt welds shall be inspected by radiographic or ultrasonic methods. The ministry may require additional testing on a project by project basis and shall clearly specify such in the tender documents.

4.5 Steel Piles

4.5.1 Material Standards

Material for H piles and for end plates for pipe piles must conform with CAN/CSA-G40.21-M, Grade 300. Steel pipe for pipe piles must conform with ASTM specification A252, grade 2. Pipe steel must meet ASTM specification A53. Substitution of any materials from the above must be pre-approved by the ministry.

4.5.2 Welding Standards

Where pile welding is required, the welding must be undertaken by a company approved by the Canadian Welding Bureau to the requirements of CSA W47.1, division 3 or better.

4.5.3 Splicing of Piles

Where pile splicing is necessary, it must be done in accordance with the details shown on the drawings prepared by the engineer.

4.6 Concrete

4.6.1 Standards

Concrete must be designed, mixed, transported, cast and cured according to CSA Standard A23.1, Concrete Materials and Methods of Concrete Construction and tested to CSA Standard A23.2, Methods of Test for Concrete.

Precast concrete bridge elements must conform with CSA Standard A23.4, Precast Concrete-Materials and Construction. Precast concrete manufacturers (with the exception of lock block manufacturers, see 4.6.5) must be selected from the appropriate category in the “List of CSA Certified Precast Concrete Plants,” Dir. 007, current edition. All concrete must be certified by a laboratory selected from the “List of CSA Certified Concrete Testing Laboratories,” Dir. 011, current edition.

In addition to the above, prestressed concrete members shall be fabricated in accordance with Appendix F, “Manufacture of Prestressed Concrete Members”.

4.6.2 Design Mix

Concrete mixes must meet the requirements shown in Table 3.

Table 3. Requirements for Concrete Mixes

Bridge element	Min. compressive strength at 28 days	Max. nominal size of aggregate	Air content (%)	Slump (mm)	Max. w/c ration by mass
Deck slab	35 Mpa	20 mm	5 ± 1	30 ± 20*	0.38
Deck overlays and keyways	35 Mpa	12 mm	6 ± 1	20 ± 10	0.35
Piers, abutments and footings	30 Mpa	28 mm	5 ± 1	50 ± 20	0.45
Filling pipe piles	30 Mpa	28 mm	5 ± 1	50 ± 20	0.50

*± 40 where superplasticizer is used.

4.6.3 Formwork

Formwork for cast-in-place concrete must be designed, supplied, and installed in accordance with CAN/CSA-S269.3-M.

4.6.4 Grout

All grout shall be placed in accordance with the manufacturer’s directions. Emaco T415 (or approved equivalent) shall be used for cold weather applications and Target Traffic Patch (or approved equivalent) shall be used for all other applications.

For concrete deck panel grout joints on composite steel bridges with spans greater than 25 m, specialized grouts with superior resistance to cyclical loads shall be considered.

4.6.5 Lock Blocks

Lock blocks may be supplied by a non-CSA certified precast plant provided they meet the following specifications:

- Concrete must have a minimum 28 day strength of 20 MPa unless otherwise specified.
- Blocks must not have any cold joints.
- The finish must not be honeycombed.
- Dimensional tolerance must be ± 20 mm for length, width and height and the blocks shall be reasonably square, with the diagonals within a tolerance of ± 15 mm of each other.
- Top and bottom surfaces must be flat to a tolerance of ± 3 mm under a 600 mm straight edge.

- Where maintaining visual quality of exposed blocks is a concern, concrete shall be air entrained $5 \pm 1\%$ to protect the surface from freeze thaw degradation.

Before a new supplier is approved to supply lock blocks to the ministry for bridge projects, the ministry shall inspect the supplier's operation and a sample of their product for conformance to the above specifications.

4.7 Reinforcing Steel

4.7.1 Standards

- Reinforcing steel, including tendons, must meet the requirements of CSA Standard A23.1, Concrete Materials and Methods of Concrete Construction, and/or CSA Standard A23.3, Fabrication and Placement of Reinforcement.
- Non-prestressed reinforcement must conform with CSA Standard G30.18.
- Welded wire fabric must conform with CSA Standard G30.5 or G30.15.
- Deformed wire for concrete reinforcement must conform with CSA Standard G30.14.

4.7.2 Epoxy Coating

In adverse conditions, such as a bridge deck that will be regularly exposed to road salt or portions of structures in the splash or spray zone of salt water, epoxy-coated reinforcement shall be specified.

4.8 Timber

4.8.1 Materials Standards

Timber used for bridge construction must be graded in accordance with the standard grading rules of the National Lumber Grades Authority. Timber must be grade-stamped, with the exception of unfinished or rough timber (in which case a grading certificate may be requested), or of local log stringers. The species used for log stringers must be as specified by the design engineer.

All sawn timbers for structural applications must be Douglas fir-larch No. 2 grade or better except timber curbs maybe any species No. 2 grade or better.

Unless otherwise specified by the engineer, the appearance grade of timber must be Industrial and the service grade Exterior.

4.8.2 Pressure Treatment

Where timber elements are specified to be pressure-treated in accordance with CSA Standard 080-28, they must be either coastal Douglas-fir or western hemlock. The timbers must be frame-cut before treatment. In the event that cutting becomes absolutely necessary after treatment, the cut surfaces must be saturated with preservative according to CSA Standard 080-M4.

Pressure treatment shall follow the guidelines in the most current edition of *Best Management Practices for the Use of Treated Wood in Aquatic Environments*, available from the Canadian Institute of Treated Wood, 202-2141 Thurston Drive, Ottawa, Ontario, K1G 6C9 (613) 737-4337 fax (613) 247-0540.

4.8.3 Connectors

Bolts used in timber connections must be in accordance with ASTM A-307 or a pre-approved equivalent specification, hot-dipped galvanized, complete with malleable iron washers and galvanized nuts.

4.9 Other Materials

All other material must be used in accordance with the manufacturer's specifications and relevant CSA standards.

5. FABRICATION, INSPECTION AND REPORTING

All pre-fabricated bridge components for Ministry of Forest bridges shall be inspected in the plant by a ministry-appointed inspector. No work shall leave the plant until the inspector has declared the materials were produced in accordance with the approved designs and drawings.

5.1 Ministry Inspector's Qualifications

The ministry will appoint a plant inspector who is a professional engineer registered in British Columbia, or another person with adequate technical knowledge and experience working under the direction of the engineer. The inspection forms must be signed by the professional engineer.

5.2 Notice to Ministry Inspector

It is the fabricator's responsibility to give notice to the ministry-appointed inspector at least 72 hours before each scheduled inspection. A shorter notice period may be accommodated by mutual agreement for individual projects as and when required. No work may proceed until after the scheduled inspection and the inspector's satisfactory review of work so far completed.

5.3 Steel Fabrication Quality Control

Independent of the quality assurance inspections by the ministry's inspector, the fabricator must carry out an ongoing quality control program as required by the appropriate division of CSA Standard W47.1 and CSA Standard W59.

5.3.1 Ministry Inspection Scheduling

The ministry inspections must be scheduled at the following stages during fabrication, as a minimum:

- prior to welding, which includes:
 - verification of material mill certificates, all material dimensions and layout
 - verification of welding equipment, consumables, welding procedures and welder's qualifications.
- on completion of welding and before shipment, which includes:
 - verification of weld locations, sizes, profiles and workmanship
 - verification of finished dimensions, camber, sweep.

5.3.2 Welding Controls

Prior to Welding

Before welding, the fabricator must ensure that:

- only documented materials are used for the project;
- all materials intended for incorporation into bridges or bridge components are examined after cutting for size, shape and quality;
- before assembling any plate girders or complex parts, the surfaces of all materials are examined for imperfections and the joint edge preparation for all groove welds verified as conforming with the Canadian Welding Bureau's approved welding standards and are within the acceptable tolerances;
- after assembling any plate girders or complex parts, and before starting the strength welding, the assembly is checked for dimensional conformance;
- any non-conformance is resolved;
- welding procedures (and accompanying proof that the welds are Canadian Welding Bureau pre-qualified) are available for review by the inspector.

During Welding

During the welding process, the fabricator must ensure that:

- all welding on structural components is done by the company certified to CSA W47.1, division 1 or division 2.1, and in accordance with the Canadian Welding Bureau's approved welding standards;

- the edge preparations for all groove welds conform to the dimensions established in those standards;
- the strength level and chemical composition of all filler materials used in structural assemblies conform to the approved shop drawing details;
- all welding consumables conform to the standards and are received, stored and conditioned to the standards;
- any preheating required before welding is done according to the standards;
- the welding procedure, including the use of treatment in welding any joint in a structural component, conforms to the standards.

Welder Qualifications

All welders, welding operators and welding procedures must be qualified under the requirements of the CSA Standard governing certification.

5.3.3 Non Destructive Testing

Non-destructive testing is the responsibility of the fabricator and shall be conducted in accordance with Section 4.4.2. If non-destructive testing of welded joints reveals imperfections, the fabricator must correct the quality of welds to the inspector's satisfaction at the fabricator's own expense.

5.3.4 Ministry Inspector's Responsibilities

The inspector must complete all inspections required to complete the form Quality Assurance for Steel Fabrication Inspection Report: Steel Products (see Appendix D) and forward the signed form, copies of mill certificates, copies of test results and any other pertinent information to the Ministry of Forest Regional Engineering Officer or other ministry contact responsible for the bridge.

5.4 Precast Concrete Fabrication Quality Control

Independent of the quality inspections by the ministry's inspector, the manufacturer must carry out an ongoing quality control program, as required by the most current edition of CSA Standard A23.4.

5.4.1 Ministry Inspection Scheduling

The ministry inspections must be scheduled at the following stages during fabrication as a minimum:

- pre-pour inspection (to current CSA Standard A23.4 and project documentation), which includes:
 - inspection of forms for size, shape and quality
 - inspection of reinforcement for quantity, quality, shape, spacing, size and placement in forms.
- post-pour inspection and reporting, during which:
 - dimensions of all elements must be verified to ensure tolerances are being maintained as per the specifications
 - finishes, blockouts, keyways and epoxy protection of the cut-off strands (prestressed only) must be verified
 - camber or crown must be checked, as per project drawings
 - all non-conformities must be corrected to the inspector's satisfaction.

5.4.2 Storage and Curing

Elements must be stored and cured according to the manufacturer's documented procedures and in accordance with the most current edition of CSA Standard A23.4. In addition, prestressed concrete members shall be fabricated, cured and handled in accordance with Appendix F, "Manufacture of Prestressed Concrete Members".

5.4.3 Ministry Inspector's Responsibilities

The inspector must undertake all inspections required to complete the form Quality Assurance for Precast Concrete Fabrication Inspection Report: Precast Concrete Products (Appendix D). The inspector shall forward the signed form, copies of material certificates, copies of test results and any other pertinent information to the Ministry of Forest Regional Engineering Officer or other ministry contact responsible for the bridge. The inspector shall forward the 28-day concrete test results separately at a later date so the ministry receives the reports in a timely fashion.

6. TRANSPORTATION AND CONSTRUCTION

6.1 Transportation

Concrete elements shall be transported after the 28-day design strength has been achieved unless the design engineer has confirmed in writing or indicated on the drawings that the elements can be shipped at a lower strength than the 28-day strength. Prestressed concrete members shall be transported in accordance with Appendix F, "Manufacture of Prestressed Concrete Members".

6.2 Instream Work

Approvals from regulatory agencies (Department of Fisheries and Oceans and the Ministry of Environment Lands and Parks) shall be obtained for works in and about streams. In addition to the above approvals, the following practices shall be followed.

Construction shall be carried out in such a manner as to ensure water quality is maintained by keeping soil erosion and run-off to a minimum. Measures shall be taken to prevent sediment, leachate, fresh concrete and demolition and construction debris from entering the wetted perimeter. In addition, the following measures shall be followed:

- Machines that enter the water must not have fluid leaks.
- Bridge girders and deck components shall be cleaned just prior to launching or erection.
- Excavations shall be isolated from running water using temporary sediment containment methods; sediment laden water shall be pumped out of the containment areas to the bush where sediment will settle and filter prior to entering any watercourse, prior to backfilling or removal of containment measures. If necessary a settling area shall be constructed to prevent sediment laden water returning to the stream.
- No unnecessary crossings or encroachment by equipment on the wetted perimeter shall occur.

6.3 Design Engineer's Responsibility

6.3.1 Loading Specifications

The design engineer must consider transportation and construction procedures as part of the design of the bridge. Location of girder support and lift points must be noted on the drawings. The weight of materials, work crews and equipment supported during construction must be considered by the design engineer, who must specify maximum permissible construction equipment loads. The erection procedure assumed for the design must be shown or described on the drawings.

6.3.2 Drawing Notes

The design drawings must require that the bridge erector obtain the actual equipment loads from the equipment manufacturers and confirm them with the design engineer.

6.4 Bridge Erector's Responsibilities

The bridge erector responsible for bridge installation must notify a local officer of the Workers' Compensation Board about the planned date of installation and is responsible for ensuring that all work carried out during construction of the bridge is in full conformance with the Workers' Compensation Board regulations.

The bridge erector shall follow the bridge erection procedures prepared by the design engineer or an alternative procedure prepared by another engineer.

6.5 Construction Tolerances

Where construction tolerances are **not** shown on the drawings, the bridge elements below shall be laid out and constructed so final locations shall not differ from the positions shown on the drawings by the following tolerances:

Horizontal location of bridge superstructure:

longitudinal direction

± 150 mm

transverse direction

± 50 mm

Horizontal location of substructure elements relative to superstructure:

pile heads, posts, footings, retaining walls ± 50 mm

Maximum deviation from plumb or specified batter for:

piles

20 mm per meter

posts

5 mm per meter

Horizontal location of anchor bolt groups ± 15 mm

Vertical location of bridge seats ± 10 mm

Any deviation from the final drawings beyond the above tolerances shall be satisfactorily corrected by the Recipient at his own expense.

6.6 Construction Inspection and Professional Certification

All Ministry of Forest bridges and major culverts require certification by a professional engineer to ensure the bridge was constructed in accordance with the drawings and specifications. The certifying engineer must work independently and at arms length to the bridge contractor, except in the following 2 cases:

- For bridges where there are no piles or embedded posts, and where all structural components are substantially visible and above ground on completion (ie. bridges on shallow sills and retaining walls), the bridge contractor's engineer may certify the bridge.
- For bridges constructed by a Forest company's own employees (ie. where the forest company is the bridge contractor).

NOTE: It is not acceptable for the certifying engineer to rely upon data or information provided during construction by the bridge contractor. In addition, the certifying engineer must carry out the final inspection as a minimum. One of the following scenarios may be selected:

- The certifying engineer carries out all site inspections.
- The certifying engineer directs/supervises an individual (who may work for the same firm as the certifying engineer, or for an independent sub-consultant) to carry out some or all of the site inspections, other than the final inspection.

6.6.1 Site Inspections

The requirements for, and timing of, site inspections required during construction must be specified by the certifying engineer prior to construction. Site inspections might be required during pile driving, before cast-in-place concrete is poured into place, during the launching of girders, during site welding and at other critical points during construction, to ensure that all works are performed according to the drawings and specifications.

The certifying engineer shall submit the form FS137 (Assurance of Field Reviews - sample in Appendix C) to the ministry prior to commencement of the work at the site. This form must be completed and signed by the professional engineer who will be providing certification. The engineer shall indicate on the form FS137, the field reviews which will be undertaken by the engineer to ensure that all aspects of the work substantially conform to the approved design.

6.6.2 Site Inspector's Qualifications

The site inspector must be a professional engineer registered in British Columbia, or another person with adequate technical knowledge and experience, for whose work the professional engineer is fully responsible. The certification must be signed by the professional engineer.

6.6.3 Certification of Construction

Each bridge construction project will be considered complete only upon satisfactory professional certification.

Upon completion of construction, a professional engineer must certify that the entire structure is in general conformance with the design drawings and specifications, and conforms in all aspects with the original design intentions. The Certification of Construction, FS 138 (sample in Appendix C), shall be completed and signed by the certifying engineer.

6.6.4 As-built Documentation

As-built documentation shall be prepared either by the ministry, or on behalf of the ministry, for all Forest Service bridges, and shall include the following:

- field inspection reports
- test results, material certificates
- design and as-built drawings and specifications
- certification of construction form FS138
- as-built record forms FS1051ABC.

As-built drawings shall include details of any changes from the design drawings that are pertinent to the overall performance of the structure such as:

- pile penetrations and locations, etc.
- modified connection details
- use of alternative materials
- modified riprap locations
- substituted foundation type etc.

6.7 Site Cleanup

All project sites must be cleaned up following completion of construction and before final demobilization. Site cleanup shall include the removal of all equipment, materials, trash, equipment refuse and construction debris, and removal of dirt and debris on the bridge girders, decks and bearings.

APPENDIX A Standard Drawing List

The *Bridge Design and Construction Manual* and the standard drawings can be downloaded, in PDF file format, from the Ministry of Forests, Resource Tenures and Engineering Branch website: http://www.for.gov.bc.ca/hth/engineering/publications_guidebooks.htm

A Standard Drawing List is available at the above-noted site.

APPENDIX B VEHICLE LOADING DIAGRAMS

Logging truck design loads on forest road bridges

Ministry of Forests

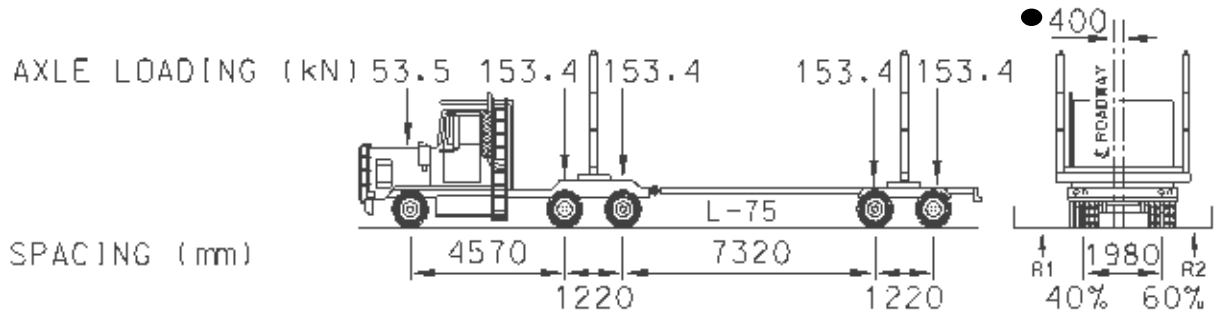

L-75 (OFF HIGHWAY) GVW 68,040 kg

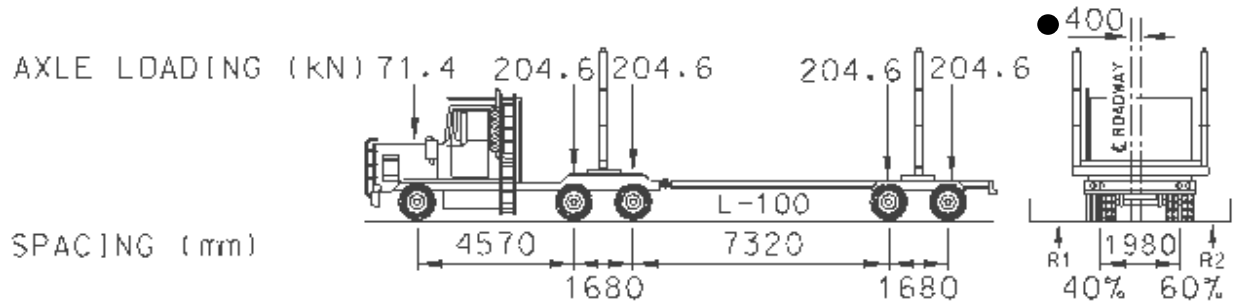

L-100 (OFF HIGHWAY) GVW 90,680 kg

- Above eccentricity applies only to bridges with 2 girders 3000 apart.
For non standard deck widths, increase eccentricity by 50% of deck width over 4300.

VEHICLE LOADING DIAGRAMS

Logging truck design loads on forest road bridges

Ministry of Forests

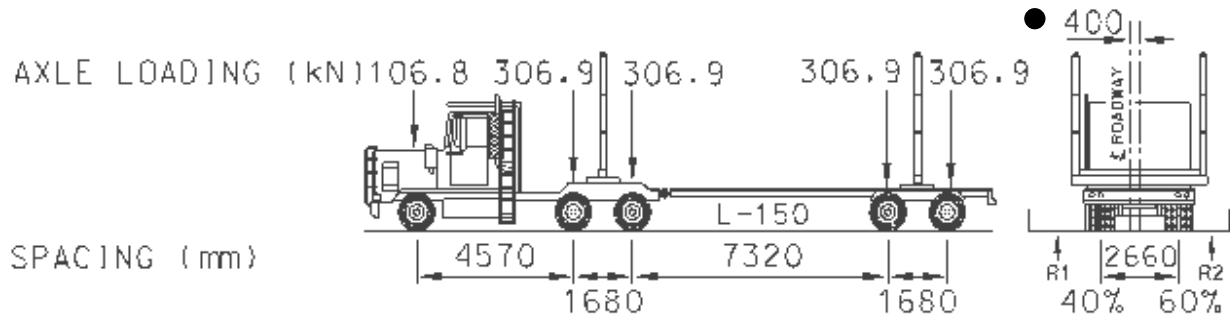

L-150 (OFF HIGHWAY) GVW 136,090 kg

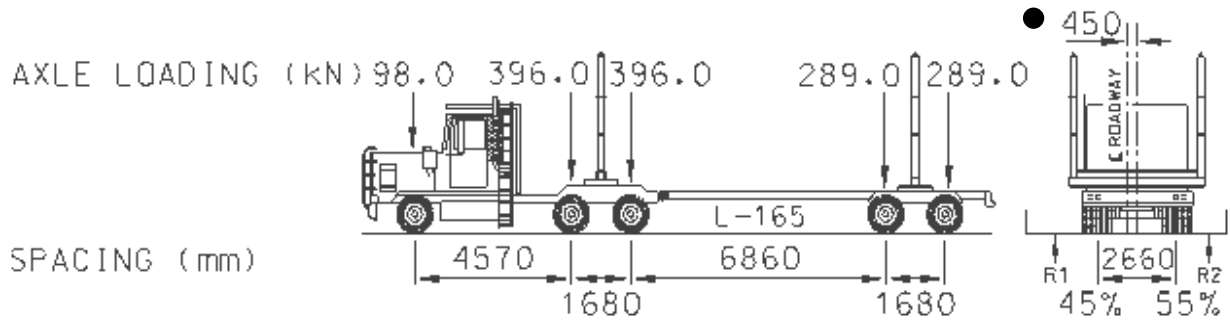

L-165 (OFF HIGHWAY) GVW 149,700 kg

- Above eccentricity applies only to bridges with 2 girders 3600 apart. For non standard deck widths, increase eccentricity by 50% of deck width over 4900.



Province of
British Columbia

Ministry
of Forests



APPENDIX C

ASSURANCE OF FIELD REVIEWS
(CONSTRUCTION OF BRIDGES AND MAJOR CULVERTS)
*TO BE SUBMITTED **PRIOR** TO CONSTRUCTION*

PROJECT	
ROAD	
DISTRICT	REGION

The undersigned hereby gives assurance of being responsible for structural “field reviews” of the above-mentioned structure.

As used herein, “field reviews” shall mean such reviews at the project site (and at fabrication site, where required or applicable) considered necessary by, and at the professional discretion of, the engineer to ensure that all aspects of the work substantially conform to the plans and supporting documents prepared for the project and “accepted” by the Ministry. This will include keeping records of all site visits and of any corrective actions taken as a result thereof, and submittal of copies of all documents to the Ministry’s Regional Engineer.

The undersigned also undertakes to notify the Regional Engineer as soon as practical if the contract for field reviews is cancelled at any time during construction.

SCHEDULE OF PLANNED FIELD REVIEWS			
VISIT NO.	ITEMS TO BE INSPECTED		
ENGINEER’S SIGNATURE (Registered as P.Eng. or P.Geo with APEGBC)		ENGINEER’S NAME (<i>please print</i>)	DATE SIGNED Y M D
COMPANY NAME (<i>please print</i>)		PHONE NO.	FAX NO.
COMPANY ADDRESS			

FS 137



Province of
British Columbia

Ministry
of Forests



**CERTIFICATION OF CONSTRUCTION
OF BRIDGES AND MAJOR CULVERTS**
TO BE SUBMITTED AFTER COMPLETION OF THE PROJECT

PROJECT
ROAD

Forest Service Bridge Design and Construction Manual

DISTRICT	REGION
----------	--------

This is to advise that I am the Professional Engineer, registered with the Association of Professional Engineers and Geoscientists of British Columbia (APEGBC), and was retained to undertake and co-ordinate all field reviews required with respect to this project, and that I have taken all steps as regulated under the Provincial Statute for my profession and required by good practice and by the definition of "field reviews", in order to issue the following certification.

As used herein, "field reviews" means such reviews of the work at the project site (and/or the fabrication locations, where applicable) considered necessary by, and at the professional discretion of, the Registered Professional to ensure that all aspects of the work substantially conform to the plans and supporting documents "accepted" by the Ministry for the project.

All aspects of project execution have been reviewed, either by me or under my direction, and are to my satisfaction.

I certify that all aspects of the construction work substantially complied with the plans and supporting documents, including all amendments, which supported the acceptance of the project by the Ministry.

In addition, significant revisions to the accepted plans and supporting documents ("Issued for Construction") have been documented and marked on the plans or described in documents, and all have been noted in an "as-built" set and submitted to the Ministry, and the structure has a level of durability and resistance at least equal to that expected from a structure documented by the approved drawings and specifications.

SIGNATURE OF REGISTERED PROFESSIONAL		<i>(please affix professional seal here)</i>
NAME OF REGISTERED PROFESSIONAL <i>(please print)</i>	DATE SIGNED Y M D	
ADDRESS <i>(please print)</i>		
PHONE NO.	FAX NO.	

FS 138

APPENDIX D

Ministry of Forests: Quality Assurance for Steel Fabrication

Inspection Report: Steel Products _____ Page 1 of 2

Project No.: _____ Product: _____ Fabrication Start Date: _____

Bridge Name: _____ Bridge No.: _____

Fabricator: _____

MOF Contact: _____ Licensee: _____ Contractor: _____

Item No.⇒	1	2	3	4	5	6
PRIOR TO WELDING						
MATERIAL						
Identification of material/mill certificates						
Visual quality inspection						
DIMENSIONS						
Top flange width 1 (& width 2 if applicable)						
Top flange thickness						
Top flange (or flange section) length						
Top flange flatness, tilt						
Bottom flange width 1 (& width 2 if applicable)						
Bottom flange thickness						
Bottom flange (or flange section) length						
Bottom flange flatness, tilt						
Web depth						
Web thickness						
Web or web section length						
Stiffeners horiz/vert, bearing						
Camber						
Sweep tolerance 1/1000						
Web splicing: camber, alignment, holes						
Preparation of material, assembly						
WELDING						
Procedures approved for each process						
Electrode classification						
Consumables checked						
Weld locations						
Weld sizes, profiles						
Weld details, workmanship						
Non-destructive testing results						
PRIOR TO SHIPPING						
Finished product dimensions						
Camber						
Sweep						
Stiffeners						
Studs						
Surfaces						

Inspection Report: Steel Products

Page 2 of 2

GENERAL COMMENTS (Note overall product acceptability with remarks as above (OK, N/A or NG): 		
REMARKS:	OK	Item is of acceptable quality
	N/A	Item not applicable
	NG	Item quality is not good, needs improvement or replacement
<hr/>		
Inspector's Signature	Dates Inspected	
Engineer's Signature		
(Note dates, as applicable: Prior to welding, welding prior to shipping)		

Ministry of Forests: Quality Assurance for Precast Concrete Fabrication Inspection Report: Precast Concrete Products

Project No.: _____ Product: _____ Bed No.: _____ Cast Date: _____

Bridge Name: _____ Bridge No.: _____

Licensee: _____

MOF Contact: _____ Fabricator: _____ Contractor: _____

Item No.⇒	1	2	3	4	5	6
PRE-POUR						
Form condition & cleanliness						
Design dimensions						
Form set-up dimensions						
Squareness						
Plumbness						
Reinforcing steel						
Cover						
Strand pattern						
Stressing						
Hardware, inserts						
Block outs						
Lifting hooks						
POUR						
Consolidation						
Slump						
Top finish						
Curb finish						
POST-POUR						
Length						
Width						
Depth						
Crown						
Chamfers						
Squareness						
Plumbness						
Hardware location						
Projecting rebar						
Holes						
Strand cut-off						
Cracks & patching						
Surface textures						

GENERAL COMMENTS: Note overall product acceptability with remarks as above (OK, N/A or NG):

REMARKS: OK Item is of acceptable quality
 N/A Item not applicable
 NG Item quality is not good, needs improvement or replacement

 Inspector's Signature

 Dates Inspected

 Engineer's Signature

(Note dates, as applicable: Pre-pour, Pour, Post-pour)

APPENDIX E

Bridge and Major Culvert Site Plan Specifications

1. Site Conditions

Site conditions should be such that the ground surfaces and any existing structures within the limits of survey are clearly visible (i.e. snow free).

2. Survey Accuracy

The site survey(s) will be conducted with a theodolite/transit or total station with a relative precision not less than 1:1000 horizontally and 1:300 vertically.

Field referencing and bench marks will be established with a relative precision not less than 1:1000 horizontally and 1:300 vertically.

3. Limits of Survey

As a minimum, extend the site plan in the following directions:

- 3.1. upstream to show any bend which may influence the current pattern at the site, either at normal stage or in flood (generally, assume a distance up to seven (7) stream widths or to the second bend, minimum of 20 meters);
- 3.2. downstream three (3) stream widths, or to the limit of possible location changes; or to show all creek cross-sections, minimum 20 meters;
- 3.3. back from each bank to cover potential overflow channels, or to well above the high water mark;
- 3.4. along the existing or proposed road location a minimum of 50 m back from each existing or proposed abutment, or far enough to show approach problems. The surveyed area must be large enough to cover possible bridge and road location changes.

Establish a control traverse to gather site information and tie to the road P-line.

Minimum limits may need to be extended to capture additional information necessary to complete the design. In the case of existing crossing structures, limits may need to be extended in order to capture stream information beyond the influence of the existing crossing.

For replacements of culvert or other structures which are determined to be impediments to fish passage, long profiles of the stream thalweg, well beyond the influence of the existing structures, should be taken such that the designer can assess the appropriate vertical elevation and alignment of a replacement structure. Stream widths should be obtained beyond the influence of the existing crossings such that a new crossing can be designed to accommodate the natural stream width.

Consult with the designer prior to conducting a site plan for extent, scope of survey limits and any other site specific requirements.

4. Field References for Survey and Construction Layout Control

4.1. References Points

Establish a minimum of two (2) reference points at each site to allow for relocation and control surveys. The references will consist of a ground hub and a reference back site in a tree or a reference ground hub back site, on tangent with a transit hub, on each side to the stream crossing. Both reference hub and backsite will be placed out of the right-of-way to avoid disturbance.

4.2. Bench Marks

Establish at least two (2) bench marks, for elevation reference, away from any potential disturbance, to be placed on firm fixed objects which will not be disturbed, one on each stream bank. Preferably place the bench marks where they will be visible from both proposed bridge abutments and within 1500 mm above high water level and in a manner to allow for a survey level rod to be

placed on the bench mark. Where elevations have not been established, use reference elevation datum of 100.000 m and note as "assumed datum of 100 m". Generally install 200 mm spikes in the side of a blazed, live tree (greater than 50 mm diameter), using the head as a bench mark and mark the bench mark with paint, ink marker and flagging.

4.3. Construction Reference Layout Stakes/Hubs/Spikes

In order to facilitate simple reference for construction layout, establish a minimum of two (2) pairs of offset construction reference ground stakes/hubs or 200mm spikes, to the existing center line or anticipated P-line at each site, to allow for establishment of the location of the proposed bridge center line with horizontal measurement using tapes. Use more durable approaches (ground hubs or spikes) unless otherwise directed. Place a pair of stakes/hubs/spikes on each side of the crossing, right and left of the center line, away from potential disturbance and preferably outside the right-of-way. Where possible, stakes should be placed at approximately the same elevation as the road surface to allow for level, tape measurement.

5. Data Collection

- 5.1. Present Water Level (PWL): Collect spot elevations every 15 m along both sides of stream to an accuracy sufficient to determine stream surface slopes.
- 5.2. High Water Level (HWL): Collect spot elevations where evidence is clear; note evidence.
- 5.3. Stream flow pattern: use floats dropped at several points across the stream to collect relative flow velocities. Note measured velocities; signs of bank erosion (overhanging trees and roots, vertical banks, areas where present channel differs from that in older air photos).
- 5.4. Site features: note sloughs, abandoned channels, overflow channels, sand or gravel bars, bed rock, boulder areas, log jams, debris accumulations, fords, vegetation boundaries, trails, ice-jam areas or other significant features.
- 5.5. Note descriptions and boundaries of soil and rock types as seen on the surface, including stream bed substrate, particularly where exposed rock may affect bridge structure or abutment location. Note any test hole locations and their logs. For existing bridge structures within the limits of survey obtain:
 - a) spot elevations for each corner of the existing deck and/or edges of existing traveled road surface;
 - b) spot elevations for the upper corners of the existing abutments;
 - c) spot elevations showing the perimeter of the abutments where they contact the ground surface and outline the edges of the existing bridge;
 - d) outline of the outside perimeter of the existing structure.
- 5.6. Other existing:
 - a) structures such as: buildings, fences, roads, driveways and gates;
 - b) utilities such as: power poles with numbers of , height of, and direction of wires; gas lines with any surface markings and structures;
 - c) right-of-way markings such as: Forest Service Road, pipe line, gas line, easement, railway and power line R/W pins.
- 5.7. Descriptive photographs shall be taken to show the bridge crossing site. At minimum, photographs of each streambank from the opposite streambank and from the upstream and downstream of the proposed or existing bridge site shall be taken. Where difficult and convoluted ground or soil conditions occur, additional photographs shall be taken at the time of the data collection detailing conditions.

- 5.8. In addition to collecting sufficient data points for production of the site plan drawing, carry out the following profiles and cross-sections:
 - a) For proposed crossings, take a center line profile, including soundings where appropriate, of the expected crossing line to include approach alignment (a minimum of 50 m each side or adequate distance to resolve any approach or alignment problems), high water line, present water line, wetted perimeter, top of banks and other topographic features.
 - b) If the downstream reach is uniform, take one other section about three to five stream widths (minimum 15 meters) below center line and the same upstream. If flow is non-uniform, take two or more sections below center line at points of change, and do the same upstream.
 - c) Where a bridge structure exists, cross sections shall be taken, parallel to the center line, along the upstream and downstream edge of the bridge to show stream bed and ground lines adjacent to the abutments.

6. Plan Details

Using a preferred scale of 1:200, plot the following information on the plan drawing:

- 6.1. The designation, location, and description of reference points and the bench marks, including elevation and datum;
- 6.2. Contours: the contour interval shall be 0.5 m; this may have to change on rock cliffs; make a conspicuous warning note if two intervals are used on the same plan; show all cross-sections and points read; extend contours across the stream bed where possible particularly at the proposed crossing location and at possible sites for a work bridge or ford; accuracy should permit interpolation to a 0.3 m error on rock, around existing bridge structure components and along the stream banks;
- 6.3. PWL and date of data collection; show spot elevations every 15 m along both sides of stream to an accuracy sufficient to determine stream surface slopes;
- 6.4. HWL; show spot elevations where evidence is clear and if possible join with a dashed line; describe evidence;
- 6.5. Stream flow patterns; use floats dropped at several points across the stream to collect relative flow velocities; note measured velocities; indicate signs of bank erosion (overhanging trees and roots, vertical banks, areas where present channel differs from that in older air photos);
- 6.6. Existing bridge structures show:
 - a) spot elevations for each corner of the existing deck (indicate "deck");
 - b) spot elevations for the upper corners of the existing abutments (indicate as "top abut" or "top crib");
 - c) spot elevations showing the perimeter of the abutments where they contact the ground surface; and
 - d) outline of the perimeter of the existing structure;
- 6.7. Show and label significant features from data collection such as sloughs, abandoned channels, overflow channels, sand or gravel bars, boulder areas, log jams, debris accumulations, fords, vegetation boundaries, cabins, trails, ice-jam areas or other significant features. Provide descriptive notes to describe such features;
- 6.8. Show and describe boundaries of soil and rock types as seen on the surface, including the streambed, particularly where exposed rock may affect bridge structure or abutment location. Show test hole locations and their logs;
- 6.9. Other existing structures, utilities and rights-of way;
- 6.10. Vegetation boundaries and types;

- 6.11. Location of stream cross-sections taken;
- 6.12. Land status and right-of-way boundaries, where known;
- 6.13. Control traverse;
- 6.14. North Arrow and magnetic declination;
- 6.15. Key map showing location of bridge site, direction and distance to town, ;
- 6.16. Legend of symbols and lines;
- 6.17. Scales;
- 6.18. Title Block showing: bridge structure number, FSR or forest road name, kilometer location, stream name, who completed the survey, who completed the drawing, date of survey, and drawing number.

7. Profile/Cross Section Drawings

Show the following information:

7.1. Profile/Cross Sections

a) Scales:

Creek Cross Sections: 1:200 Horizontal and Vertical

Road Center Line Profile: 1:200 Horizontal and Vertical on existing/proposed bridge center line.

Detail Bridge Center Line Profile: 1:100 Horizontal and Vertical (detail of previous extending 10m each side of bridge).

Creek Center Line Profile: 1:200 Horizontal and Vertical.

- b) Show the ground and stream bed elevations along the existing or proposed road and bridge center line.
- c) Extend the center line ground profile at least 50 m beyond either end of existing or proposed bridge along the existing or proposed road center line. A stationing of 0+000 used at the beginning of and at the town side of the survey.
- d) Where a bridge structure exists, on the same drawing, using distinct line types, show the stream bed and banks along the upstream and downstream edge of the bridge (where possible), show ground lines adjacent to the abutments.
- e) Show the present water level and right bank/left bank.
- f) Show high water level.

7.2. Stream bed/surface water profile - using a scale of 1:200 horizontal and 1:200 vertical.

- a) Show the profile of the stream bed and water surface for the length of the site plan including stream bed gradient.

7.3. Title Block showing: bridge structure number, FSR or forest road name, kilometer location, stream name, who completed the survey, who completed the drawing, date of survey, and drawing number.

APPENDIX F

Manufacture of Prestressed Concrete Members

1. TENDON STRESSING

The dials of gauges shall be at least 200 mm in diameter. Gauges shall be calibrated, with the hoses and jacks with which they are to be used, by an approved testing agency. The calibration must have been performed within the previous six months of use or 12 months maximum. Before stressing commences, certified calibration curves shall be furnished to the Ministry.

If during the work any gauges give erratic results, the tension system or tension device shall be recalibrated.

The Contractor shall schedule the work so that placement of concrete follows tensioning of strands within 24 hours. In cases of unavoidable delay, a maximum period of 80 hours will be allowed, provided that the strands do not show unacceptable corrosion (see PCI Manual for Quality Control, Section 2.2.2).

Before tensioning, an initial force shall be applied to each strand to equalize stresses and eliminate slack. This force shall not exceed 22kN. After the initial tension forces have been applied, each strand shall be marked at the outer end of each chuck as a reference line from which the elongation of the strand can be measured.

The method of tensioning shall be such that the specified tension is maintained in the strands until the forces in the strands are transferred to the concrete member(s). The maximum jacking load in each strand shall be 85% of the ultimate strength of the strand.

A tensioning force shall be determined both by reading the jacking load on the calibrated gauge and by measuring the elongation of the strand. When the difference between the two methods is greater than 5%, the cause of the discrepancy shall be ascertained and corrected.

Elongations of strands shall be calculated and shown on the working drawings. Calculations for elongations shall include appropriate allowances for possible slippage or relaxation of the anchorages, friction at hold down points, temperature difference, and strand relaxation.

2. FORMS

All exterior forms shall be of steel and shall be mortar-tight and of sufficient rigidity to prevent distortion due to incidental loadings during construction. Forms for skewed ends may be of rigid steel-reinforced plywood.

Forms shall produce 20 mm chamfers and fillets as shown on the Drawings.

The design of the forms shall take into account the effect of vibration of concrete as it is placed.

All exterior forms shall be set and maintained true to the designated lines until the concrete has hardened. When forms are unsatisfactory in any way, either before or during the placing of concrete, the Ministry may order the work stopped until the defects have been corrected.

The shape, strength, rigidity, mortar-tightness and surface smoothness of re-used forms shall be maintained at all times. Any warped or bulged formwork must be realigned before being re-used. Forms which are unsatisfactory in any respect shall not be re-used.

Void forms shall be of an approved product and shall be anchored firmly by a means acceptable to the Ministry, to prevent displacement during the placing of the concrete. Any member with a void out of position in excess of the specified tolerance will be rejected.

Exterior forms shall be treated in moderation with form oil before placing the concrete. Any material which will adhere to or discolour the concrete shall not be used.

Side forms and any attachments which would obstruct strain of the members shall be removed before transfer of stress.

3. ADMIXTURES

The Contractor shall add sufficient air-entraining agent to entrain 5%±1% air as determined by an air-meter used in accordance with the current CSA-A23.2.

The use of other admixtures, such as water-reducing agent or super plasticizer, shall be subject to the consent of the Ministry.

4. MEASUREMENT OF MATERIALS

Measurement of materials shall conform to the current CSA-A23.1. The Contractor shall produce a certificate of accuracy for the batching equipment from the Dominion Government Weights and Measures Division which is not over 6 months old. Cement in standard packages need not be weighed.

The surface moisture shall be determined in accordance with the current CSA-A23.2 and the batch weights of aggregates and water adjusted accordingly.

5. MIX REQUIREMENTS

Minimum compressive strength at time of transfer of stress to the concrete and at 28 days as determined by the current CSA-A23.2 shall be as called for on the Drawings.

Slump as determined by the current CSA-A23.2 shall be 50 mm ± 10 mm for concrete without super plasticizer and a maximum of 100 mm for concrete with super plasticizer.

In order to minimize shrinkage and creep the cement/aggregate ratio shall be kept as low as is consistent with strength requirements.

6. BATCHING AND MIXING

The batching plant and mixing of concrete shall conform to the current CSA-A23.1.

Mixing shall begin within 15 minutes after the cement has been added either to the water or aggregate.

Within 30 minutes after the introduction of the mixing water to the cement and aggregate, or the cement to the aggregate, the concrete shall be placed in its final position in the forms. In hot weather or under other conditions contributing to quick stiffening of the concrete, the maximum allowable time may be reduced by the Ministry.

Concrete mixing and transporting equipment shall be capable of placing concrete in the forms at the rate of 20 cubic meters per hour. Batch delivery shall be uniform and at a maximum interval of 10 minutes.

The maximum size of each batch shall not exceed the maximum rated capacity of the mixer as stated by the manufacturer of the mixer.

Concrete when placed in the form shall have a temperature not less than 10°C nor greater than 30°C .

7. HANDLING AND PLACING CONCRETE

In preparation for the placing of concrete, all construction debris and extraneous matter shall be removed from the interior of forms. Struts, stays and braces inside the forms shall be kept to a minimum and entirely removed when the concrete placing has reached an elevation rendering their service unnecessary.

Concrete shall be handled and placed in accordance with the requirements of the current CSA-A23.1 and shall be placed in the shortest possible time after mixing is completed. When rectangular void forms are used, concrete under voids shall be placed and compacted before void forms are in position.

Concrete may be deposited a maximum of 2 meters without the use of pipes, provided, when required, suitable measures are taken to prevent segregation and premature coating of upper reinforcing steel. When pipes are used they shall, as far as practicable, be kept full of concrete during placing and their lower ends shall be kept buried in the newly placed concrete.

After initial set of the concrete the forms shall not be jarred and no stress shall be placed on reinforcing bars which project.

8. VIBRATION OF CONCRETE

Concrete, during and immediately after depositing, shall be thoroughly compacted. The compaction shall be accomplished by mechanical vibration subject to the following provisions:

Vibration shall be internal for all accessible parts and shall be external for inaccessible parts.

Vibrators shall be of a type and design approved by the Ministry. They shall be capable of transmitting vibration to the concrete at frequencies recommended in the current CSA-A23.1.

The intensity of vibration shall be such as to visibly affect a mass of concrete of 50 mm slump over a radius of at least 500 mm.

The Contractor shall provide a sufficient number of vibrators to properly compact each batch immediately after it is placed in the forms.

Vibrators shall be manipulated so as to thoroughly work the concrete around the reinforcing and embedded fixtures and into the corners and angles of the forms. Vibration shall be applied at the point of deposit and in the area of freshly deposited concrete. The vibrators shall be inserted into and withdrawn from the concrete slowly. The vibration shall be of sufficient duration and intensity to thoroughly compact the concrete, but shall not be continued so as to cause segregation. Vibration shall not be continued at any one point to the extent that localized areas of grout are formed. Application of vibrators shall be at points uniformly spaced and not farther apart than twice the radius over which the vibration is visibly effective.

Vibration shall not be applied directly or through the reinforcement to sections or layers of concrete which have hardened to the degree that the concrete ceases to be plastic under vibration. It shall not be used to make concrete flow in the forms over distances so great as to cause segregation, and vibrators shall not be used to transport concrete in the forms.

Vibration shall be supplemented by such spading as is necessary to ensure a smooth surface and dense concrete along form surfaces and in corners and locations impossible to reach with the vibrators.

Vibrator heads shall be smaller than the minimum clear distance between prestressing strands.

9. TEST CYLINDERS

The Contractor shall make available, as may be required by the Ministry, samples of the concrete to be used in casting the members.

Further, the Contractor shall take samples and make test cylinders in the presence of the Ministry Representative and in accordance with the current CSA-A23.2-1C, -3C and -9C. At least 8 cylinders per casting bed shall be made for testing:

Release Strength

Two cylinders from each end of the casting bed shall be cured in the same manner as the members and tested by the Contractor under the discretionary observation of the Ministry Representative at the Contractor's plant to assess the strength of the concrete at the time of transfer of force to the concrete. Only one cylinder from each end need be tested if the average strength of the two cylinders is equal to or greater than the required release strength at transfer and no test cylinder is more than 1.4 MPa below the release strength. No transfer of force shall occur until authorized by the Ministry.

If all release cylinders are tested and the release strength has not been attained, further testing with an impact hammer shall be allowed, provided a written procedure acceptable to the Ministry is provided by the Contractor. The procedure shall correlate readings from areas of a prestressed girder where the release strengths has been determined by concrete test cylinders with similar areas on the girder in question. If this situation occurs, extra pairs of

release cylinders shall be made on future casts until confidence in determining the release strength is re-established.

28 Day Strength

Two cylinders from each end of the casting bed shall be identified as "acceptance cylinders" and shall be cured in the Contractor's curing tanks. These cylinders shall be tested by the Contractor under the discretionary observation of the Ministry Representative to determine the twenty-eight day strengths. The strength of the concrete in the member shall be taken as the average of the compressive strength of the "acceptance cylinders", however, no individual cylinder shall be more than 3.5 MPa below the specified strength and the average strength shall equal or exceed the 28 day strength.

For special cases, extra cylinders shall be made and tested if required by the Ministry. In the case of ready mix, and plant mixed concrete with no established records, extra cylinders, in addition to the release strength or 28 day strength cylinders, shall be made from each load.

10. SURFACE FINISH

Throughout the work special precautions shall be employed in formwork and concrete placing to produce a smooth and dense concrete. Exposed surfaces shall be as free as possible from form marks, fins, honey-combing and pock marking. Only a minimum amount of pointing will be allowed. Poor surface finish upon the removal of the forms shall be sufficient cause for the rejection of any member. All exposed edges shall be chamfered unless otherwise noted on the Drawings.

Roadway and walkway surfaces and surfaces to be bonded to shall be rough screeded by wood floating following initial strike off. Roadway and walkway surfaces shall be given a coarse transverse broomed finish. Surfaces to be bonded to shall be sand blasted to remove all laitance and foreign matter and partially expose the coarse aggregate. Loose sand and debris shall be washed or blown off.

The outer surfaces of the outside stringers and any other surfaces indicated on the drawings shall be given a Class 2 finish in accordance with MOTHS Standard Specifications, Section 211.16.

11. CURING

Members may be cured by steam or heat as outlined herein.

Steam Curing: The concrete shall be allowed to attain its initial set before application of steam: generally 2 to 4 hours after the final placement of concrete or as justified by previous experience and permitted by the Ministry.

After the placement of concrete, sufficient steam shall be applied during initial curing to hold the air surrounding the member at a temperature not less than 13°C.

Steam curing shall be done within a suitable enclosure to contain the steam and minimize moisture and heat losses. The enclosure shall allow free circulation of steam around the sides and tops of members and shall not be in contact with the member.

Steam at the outlets shall be at 100% relative humidity and low pressure. Application of the steam shall not be directly on the concrete or test cylinders and shall be from outlets distributed uniformly along the whole length of the member.

During application of the steam the ambient air temperature shall increase at a rate not to exceed 22°C per hour until an optimum temperature of 55°C is reached. In no case shall the ambient curing temperature exceed 80°C. The maximum temperature shall be held until the concrete has reached the transfer strength. In discontinuing the steam, the ambient air temperature shall not decrease at a rate to exceed 33°C per hour until a temperature has been reached about 11°C above the temperature of the air to which the concrete will be exposed. The forms shall not be stripped until the completion of this cooling off period.

Provision shall be made for checking the ambient air temperature either by placing minimum-maximum thermometers under the enclosure or periodically checking with hand thermometers.

Curing With Radiant Heat and Moisture - Curing with radiant heat and moisture shall be done by heating the casting area in combination with the continuous application of moisture.

Heat shall be applied by means of pipes circulating steam, hot oil or hot water or by electric heating elements. Pipes shall not be in contact with concrete, form surfaces or test cylinders.

Moisture shall be applied by a continuous sprinkling to a cover of burlap or cotton matting or any other approved method for keeping the members continuously moist.

An auxiliary cover in addition to the moisture retaining cover shall be used above the entire bed to retain the heat. This cover shall be supported at a sufficient distance above the member to allow circulation of the heat.

The cycle of application of heat, temperature limitations, reduction of temperatures and use of recording thermometers shall be similar to the cycle specified for steam curing.

12. TRANSFER

The transfer of the forces in the strands to the concrete member(s) shall be in accordance with the current CSA-A23.4 (section on Detensioning).

13. STRAND ENDS

After completion of concrete curing the ends of tensile strands shall be ground flush with the concrete surface. Where the ends of the members are to be embedded in concrete, the ends of the strands shall be painted with two coats of Ministry approved organic zinc rich paint. Where the ends of the members are not to be embedded in concrete, the ends of the members shall be covered with thixotropic epoxy to provide at least 3 mm cover. This material is to be applied in accordance with the manufacturer's recommendations.

14. TOLERANCES

For bridge stringers, the tolerances specified in the PCI Manual for Quality Control shall be modified so that the length of each member, measured parallel to the longitudinal axis, to extreme corners, at 20°C, does not exceed the specified length by more than 10 mm per 10 meter length (25 mm maximum).

The Contractor shall employ an adequate method of checking tolerances both before and after placement of concrete. Review of the method of checking tolerances by the Ministry will not limit the Contractor's responsibility for the accuracy of the members.

15. REPAIRS TO MEMBERS

Defective areas should be repaired immediately following removal of forms and before detensioning of strands. Holes, honeycomb spots, etc., shall be treated as for Class 2 finish in accordance with MOTHS Standard Specifications, Section 211.16. The method of repair for cracks, broken corners and edges, bulges and other defects shall be submitted to the Ministry Representative for review.

16. HANDLING, TRANSPORTATION AND ERECTION

Stringers shall at all times be kept in their normal upright position during handling, storage and transportation. They shall be picked up by means of vertical forces or forces inclined towards the opposite ends of the members by no more than 30 degrees from the vertical, applied to lifting devices near the ends of the stringers. I-beams shall be adequately stiffened during lifting and transportation.

Stored stringers shall rest on unyielding level supports near the ends of the stringers.

When loaded for transportation, members shall be supported so that they will not be overstressed. In general, beams with straight strands may be supported up to one-tenth of their lengths from each end, whereas beams with draped strands should be supported at their bearings. If the Contractor believes that it is possible to safely support members further from their ends, the Contractor shall submit to the Ministry, sketch(es), sealed by a registered professional engineer, showing the proposed support arrangement. Adequacy of support shall be based on the following assumptions:

- 100% impact on cantilevering ends, when checking stresses at supports,

Forest Service Bridge Design and Construction Manual

- 50% negative impact on the whole member, when checking stress near midspan,
- 50% of prestress losses at time of shipping (unless circumstances dictate otherwise),
- allowable tensile stress = $0.5\sqrt{f_c}$
- allowable compressive stress = $0.6f_c$
- where f_c = estimated strength of concrete at time of shipping.

Such sketch(es) shall be submitted at the time of submittal of the working drawings (see Section 3). Members transported on supports further from their ends than outlined above, without the submittal of sketch(es) acceptable to the Ministry, will be rejected.

Any member damaged so as to be, in the opinion of the Ministry Representative, unfit for the use for which it is intended shall be replaced at the Contractor's own expense.

APPENDIX G

Bibliography

- Certification of Welding Inspectors*, CSA Std. W178.2-1990: Canadian Standards Association
Certification to CSA W47.1: Canadian Welding Bureau
Concrete Materials and Methods of Concrete Construction, CSA Std. A23.1: Canadian Standards Association
Design of Highway Bridges, CAN/CSA-S6-88: Canadian Standards Association
Engineering Design in Wood (LSD), CAN/CSA-086.1-M89: Canadian Standards Association
Fastenings for Wood, CSA Std. 086.1: Canadian Standards Association; or ASTM A-307
Forest Road Engineering Guidebook: Forest Practices Code of British Columbia Act
Forest Road Regulation: Forest Practices Code of British Columbia Act
Fusion Welding of Steel Structures, CSA Standard W47.1: Canadian Standards Association
High-Strength Bolts for Structural Steel Joints (Metric), A325M: ASTM
List of CSA Certified Concrete Testing Laboratories, DIR.011: Canadian Standards Association
List of CSA Certified Precast Concrete Plants, DIR.007: Canadian Standards Association
Manual of Operational Hydrology B.C. Ministry of Environment, 1988
Methods of Test for Concrete, CSA Std. A23.2: Canadian Standards Association
Non-prestressed Reinforcement, CSA Std. G30.12: Canadian Standards Association
Precast Concrete - Materials and Construction, CSA Std. A23.4: Canadian Standards Association
Standard Grading Rules for Canadian Lumber: National Lumber Grades Authority
Structural Quality Steels, CSA Standard, CAN3-G40.21-M: Canadian Standards Association
Welded Wire Fabric, CSA Std. G30.5, CSA Std. G30:15: Canadian Standards Association
Welding Design and Practice, CSA Std. W59: Canadian Standards Association
Welding of Reinforcement, CSA Std. G30.16: Canadian Standards Association
Wood Highway Bridges: Canadian Wood Council
Wood Preservative Treatment, CSA 080: Canadian Standards Association
-